

# ANJASORA

CATÁLOGO GENERAL  
EDICIÓN 2

FLOOR TAPE

FLEX TONE

CONCRETE

THE STONES

THE MOSAIC

ON AREA

ANJASORA

CATÁLOGO GENERAL

EDICIÓN 2

# ANJASORA

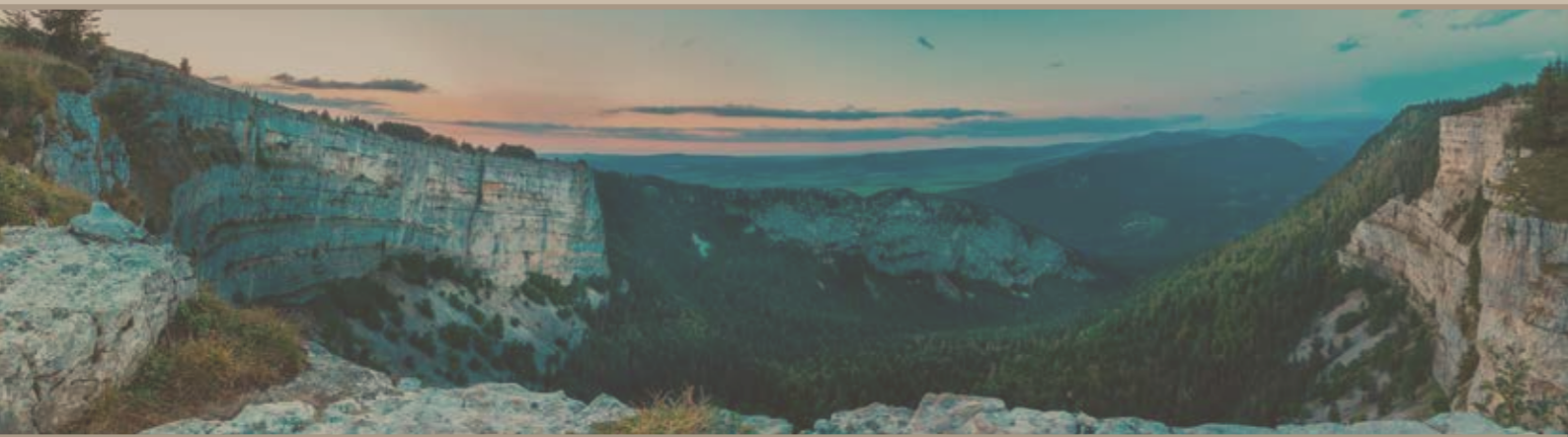

## welcome to nature

Modern life and urban rhythm drive us away from nature. However, it is when we are closer to these raw materials that our sensation of well-being and energy are significantly increased.

These collections, inspired by the finest and most precious materials, create a straight connection between interior design and nature, turning each and every project we are involved in into real spaces of relax and sensory escape.

Welcome to nature, welcome to Anjasora.

## bienvenidos a lo natural

*La vida moderna y la rutina urbana tienden a alejarnos de la naturaleza. Sin embargo, cuando nos sentimos próximos a la materia en estado puro nuestra sensación de bienestar y energía aumentan considerablemente.*

*A través de nuestras colecciones, inspiradas en los materiales más nobles y preciados, generamos una conexión directa entre interiorismo y naturaleza que convierte cada uno de los proyectos en los que participamos en auténticos espacios de descanso y evasión.*

*Bienvenidos a lo natural, bienvenidos a Anjasora.*

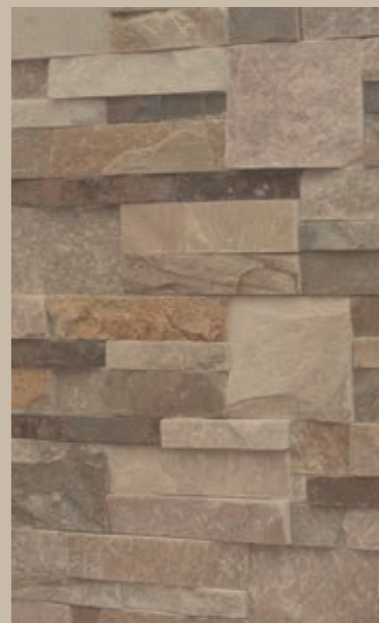
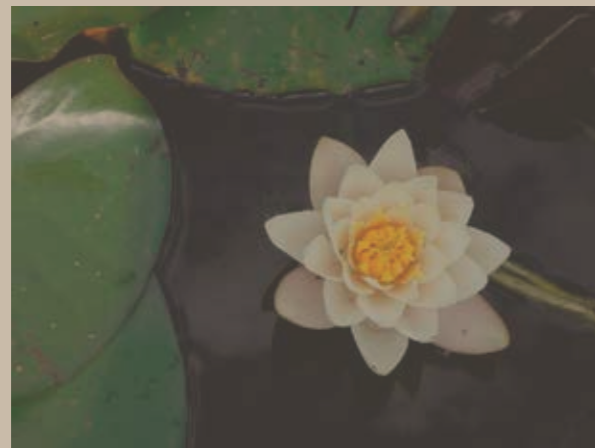

FLOOR TAPE 06

FLEX TONE 34

CONCRETE 112

THE STONES 118

THE MOSAIC 180

ON AREA 244

ANJASORA

# FLOOR TAPE

MUDEJAR	8 / 28
CALANDA	14 / 28
SARRIÓN	16 / 29
KTM 001	30
KTM 002	18 / 20
KTM 004	30
KTM 005	20 / 30
KTM 006	22 / 31
KTM 007	24 / 31
KTM 014	31
KTM 017	26 / 31

A new product range that will change the traditional concept of interior design. FloorTape is a groundbreaking material that allows fast, simple and extremely clean flooring revamps. Professionals in architecture and design seek for new solutions to create vanguard spaces in the shortest possible time. FloorTape is the perfect choice.

*Una nueva gama de producto que cambiará el concepto más tradicional del diseño de interiores. FloorTape es un material innovador que permite vestir suelos de una manera rápida, sencilla y extremadamente limpia.*

*Los profesionales del sector apuestan cada vez más por soluciones versátiles que permitan crear espacios de vanguardia en el mínimo espacio de tiempo. FloorTape es la elección perfecta.*

CERAMICTOUCH   
View it with



# MUDEJAR

## CW001

FLOOR 8,8" x 60"  
PAVIMENTO 22,5 x 153,2 cm



# MUDEJAR

## CW002

FLOOR 8,8" x 60"  
PAVIMENTO 22,5 x 153,2 cm



# MUDEJAR

## CW003

FLOOR 8,8" x 60"  
PAVIMENTO 22,5 x 153,2 cm





# CALANDA

## EW001

FLOOR 9' x 72,5"  
PAVIMENTO 23 x 184,2 cm



# SARRIÓN

FLOOR / WALL 24" x 36,6"

PAVIMENTO / REVESTIMIENTO 61,5x93 cm



# KTM 002

FLOOR 7" x 48"  
PAVIMENTO 18 x 122 cm



# KTM 005

FLOOR 7" x 48"  
PAVIMENTO 18 x 122 cm



# KTM 006

FLOOR 7" x 48"  
PAVIMENTO 18 x 122 cm



# KTM 007

FLOOR 7" x 48"  
PAVIMENTO 18 x 122 cm



# KTM 017

FLOOR 7" x 48"  
PAVIMENTO 18 x 122 cm



# FLOOR TAPE



MUDEJAR CW 001 22,5 x 153,2 M036 



MUDEJAR CW 002 22,5 x 153,2 M036 



MUDEJAR CW 003 22,5 x 153,2 M036 



CALANDA EW 23 x 184,2 M037 

	Prize Code	P./Box	SQM/Box	SQM Palet	Box/Palet	Kg/Piece	Kg/Box	Kg/Palet
MUDEJAR 22,5x153,2	M036	5	1,724	96,54	56	3,66	18,30	1.055
CALANDA 23x184,2	M037	4	1,694	94,92	56	4,50	17,99	1.037

# FLOOR TAPE



SARRIÓN LT001 61,5 x 93 M035  



SARRIÓN LT002 61,5 x 93 M035  



SARRIÓN LT003 61,5 x 93 M035  

	Prize Code	P./Box	SQM/Box	SQM Palet	Box/Palet	Kg/Piece	Kg/Box	Kg/Palet
SARRIÓN 61,5x93	M035	3	1,716	68,64	40	6,65	19,96	828



# FLOOR TAPE



KTM 001 18x122 M026 !



KTM 002 18x122 M026 !



KTM 004 18x122 M026 !



KTM 005 18x122 M026 !

	Prize Code	P./Box	SQM/Box	SQM Palet	Box/Palet	Kg/Piece	Kg/Box	Kg/Palet
KTM 18x122	M026	8	1,76	114,40	65	2,10	16,80	1.092

# FLOOR TAPE



KTM 006 18x122 M026 !



KTM 007 18x122 M026 !



KTM 014 18x122 M026 !



KTM 017 18x122 M026 !

	Prize Code	P./Box	SQM/Box	SQM Palet	Box/Palet	Kg/Piece	Kg/Box	Kg/Palet
KTM 18x122	M026	8	1,76	114,40	65	2,10	16,80	1.092

# FLOOR TAPE

## TECHNICAL SPECIFICATIONS

FloorTape's vinyl planks are designed to resist day to day challenges with a modern look inspired by the latest trends in interior design. This new solution faithfully reproduces the wood aesthetic with all the advantages that vinyl flooring provides both in installation and maintenance.

Each FloorTape slat has five layers. The first one is extremely resistance and protects the surface from any attack that could damage its appearance.

## CARACTERÍSTICAS TÉCNICAS

Las lamas de vinilo FloorTape están diseñadas para resistir los desafíos del día a día con un diseño actual inspirado por las últimas tendencias en diseño de interiores. Esta nueva solución reproduce fielmente la apariencia de la madera con todas las ventajas que los suelos vinílicos ofrecen tanto en la colocación como en su mantenimiento.

Cada lámina de FloorTape consta de cinco capas. La primera y más superficial es altamente resistente y protege la superficie de posibles agresiones que puedan dañar su aspecto.

# FLOOR TAPE



1. Scratches, stains and wear resistant protective layer.  
*Capa protectora resistente a los arañazos, las manchas y el desgaste.*
2. Decorative printed vinyl  
*Capa decorativa de vinilo impreso.*
3. High impact resistant vinyl core.  
*Núcleo de vinilo altamente resistente a los impactos.*
4. Fiberglass additional stabilising layer.  
*Capa estabilizadora adicional con fibra de vidrio.*
5. Ultra resistant vinyl strengthening.  
*Refuerzo de vinilo adicional extra resistente.*

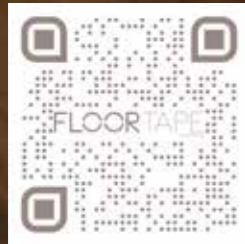

FOAM M034 (€ x m<sup>2</sup>)



SKIRTING M033 (€ x m/l)  
RODAPIÉ

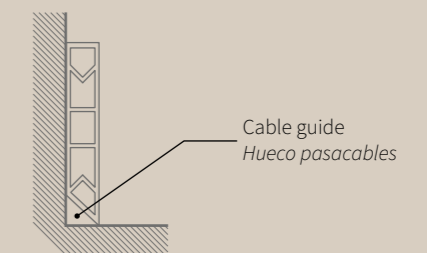

Available in all colors  
*Disponible en todos los colores*

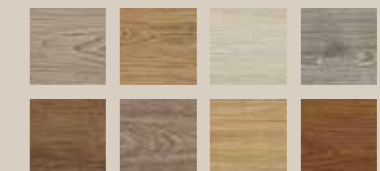

# FLEXTONE

## Format index Índice formatos

### 61x122

FS6001	36 / 40
FS6003	42 / 44
FS6004	46 / 54
FS6005	56 / 60
FS6006	62
FS6007	64 / 68
FS6008	70
FS6009	72 / 78
FS6010	80 / 86
FS6011	88 / 92
FS6012	94 / 98
FS6032	104
FS6033	102 / 104
FS6041	106 / 110

### 122x244

FSG6001	36 / 40
FSG6003	42 / 44
FSG6004	48 / 54
FSG6005	58 / 60
FSG6007	64 / 68
FSG6009	74 / 78
FSG6010	82 / 86
FSG6015	90 / 92

### BACKLIT

FS1013	38 / 40
FS1004	50 / 54
FSG1004	50 / 54
FS1007	66 / 68
FSG1007	66 / 68
FS1010	84 / 86
FS1014	92

### LAJAS

ST6003	44
ST6004	52 / 54
ST6007	68
ST6009	76 / 78
ST6010	86
ST6015	96 / 98
ST6032	100 / 104
ST6033	104
ST6041	108 / 110

## Collection index Índice colecciones

AUBURN	70	INDIAN AUTUMN	46
AUTUMN RUSTIC	80	RAINFOREST	100
BLACK LINE	36	SILVER GREY	62
COPPER HAZE	42	SILVER SHINE	72
DUSK SPRINKLE	88	S. WHITE	64
FOREST	94	TEAK WOOD	106
GOLD GREEN	56		

FLEXTONE is the lightest and most flexible natural stone you can find in the market. A 1 to 2mm thickness natural slate covered with fiberglass and polyester that provide the piece with high strength and great dimensional stability.

According to Anjasora's innovation premise, a new concept of backlight natural stone that provides warmth to any space is presented and addressed to architecture professionals.

*FLEXTONE, la piedra natural más flexible y ligera del mercado. Se trata de una lámina de piedra natural de 1 a 2mm de espesor recubierta de fibra de vidrio y poliéster que le proporciona una alta resistencia y gran estabilidad dimensional.*

*Además, en Anjasora continuamos con nuestra labor de innovación poniendo a disposición de los profesionales de la arquitectura un nuevo concepto de piedra natural con piezas retroiluminadas que proporcionan gran calidez a cualquier estancia.*

CERAMICTOUCH  
View it with 



# BLACK LINE

---

## FS6001 / FSG6001

WALL 24" x 48" / 48" x 96"

REVESTIMIENTO 61 x 122 cm / 122 x 244 cm



48" x 96"  
122 x 244 cm

24" x 48"  
61 x 122 cm

# BLACK LINE

## FS1013

WALL 24" x 48"  
REVESTIMIENTO 61 x 122 cm  
BACKLIT / RETROILUMINADO

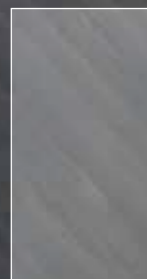

24"x48"  
61x122 cm

# BLACK LINE

WALL 24" x 48" / 48" x 96"

Backlit option / *Opción retroiluminado*

REVESTIMIENTO 61 x 122 / 122 x 244 cm



**FSG6001** 122x244 M011



**FS6001** 61x122 M009

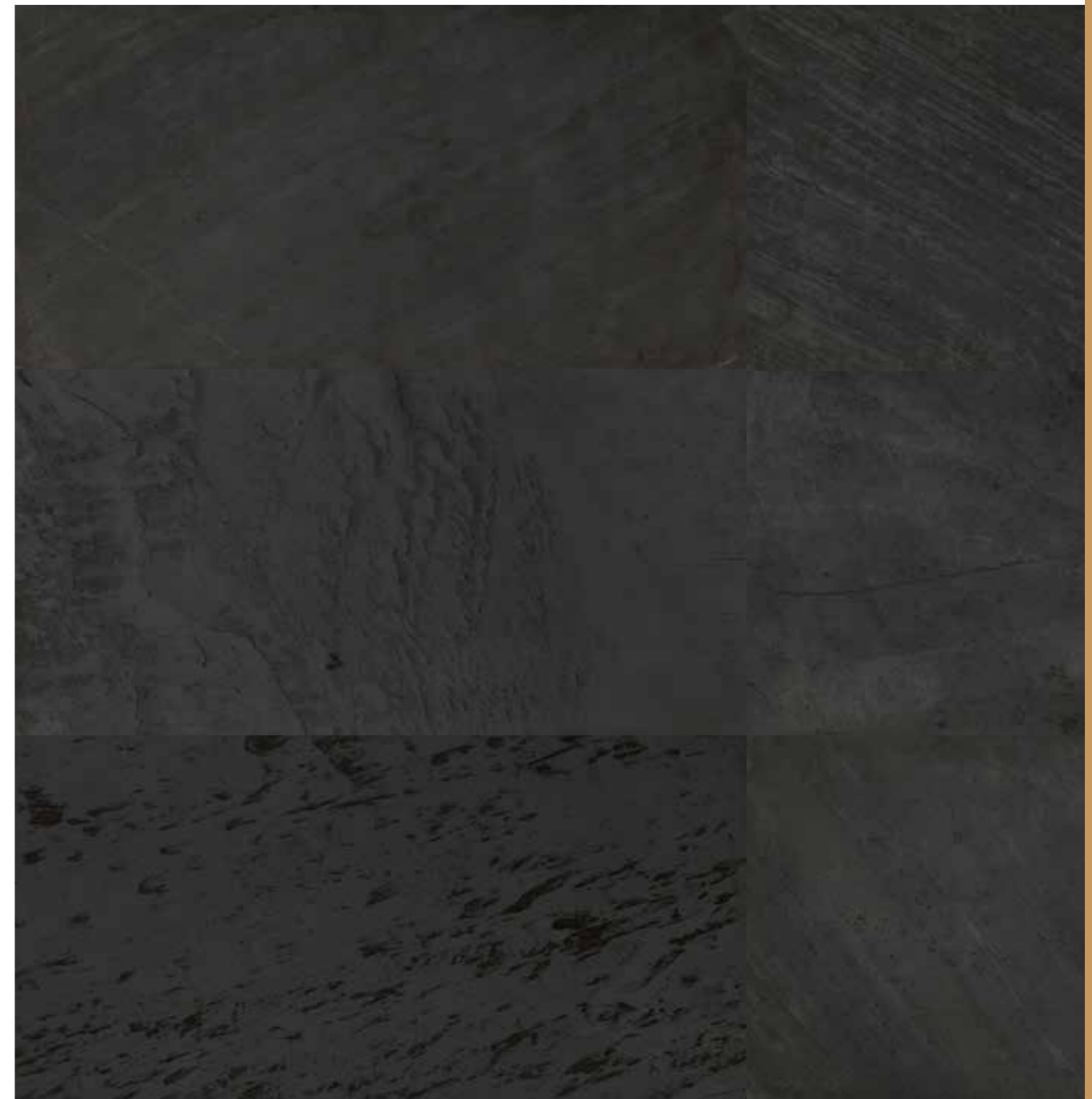

Natural variability of stones / *Variabilidad natural de las piezas*

	Prize Code	P./Box	SQM/Box	SQM Palet	Box/Palet	Kg/Piece	Kg/Box	Kg/Palet
<b>FSG6001</b> 122x244	<b>M011</b>	<b>1</b>	<b>2,98</b>	<b>223,26</b>	<b>75</b>	<b>5,12</b>	<b>5,12</b>	<b>384,37</b>
<b>FS6001</b> 61x122	<b>M009</b>	<b>6</b>	<b>4,46</b>	<b>89,28</b>	<b>20</b>	<b>1,48</b>	<b>8,91</b>	<b>178,35</b>
<b>FS1013</b> 61x122 Backlit	<b>M010</b>	<b>6</b>	<b>4,46</b>	<b>89,28</b>	<b>20</b>	<b>1,48</b>	<b>8,91</b>	<b>178,35</b>

# COPPER HAZE

---

## FS6003 / FSG6003

WALL 24" x 48" / 48" x 96"

REVESTIMIENTO 61 x 122 cm / 122 x 244 cm

48"x96"  
122x244 cm

24"x48"  
61x122 cm

5,9"x23,6"  
15x60 cm

# COPPER HAZE

WALL 5,9" x 23,6" / 24" x 48" / 48" x 96"  
 REVESTIMIENTO 15 x 60 / 61 x 122 / 122 x 244 cm



FSG6003 122x244 M011



ST6003 15x60 M025  
M032



FS6003 61x122 M009



ST6003

OPTION A - Original Flextone product for a traditional installation.  
 OPTION B - Flextone product with an adhesive base for a fixation without added materials.

OPCIÓN A - Producto Flextone original para una colocación tradicional.  
 OPCIÓN B - Producto Flextone con una base adhesiva para una fijación sin materiales añadidos.

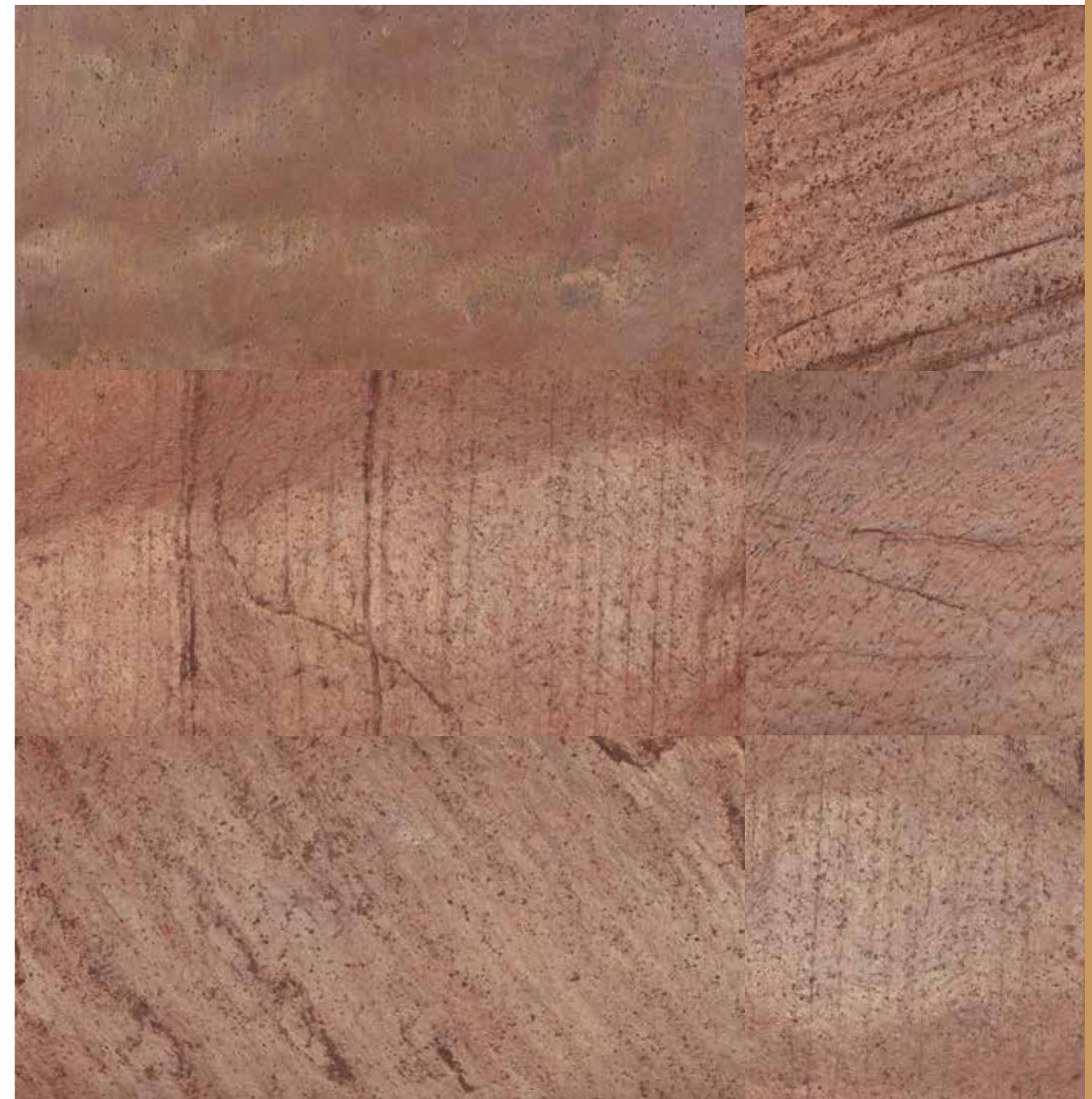

Natural variability of stones / Variabilidad natural de las piezas

	Prize Code	P./Box	SQM/Box	SQM Palet	Box/Palet	Kg/Piece	Kg/Box	Kg/Palet
FSG6003 122x244	M011	1	2,98	223,26	75	5,12	5,12	384,37
FS6003 61x122	M009	6	4,46	89,28	20	1,45	8,92	178,35
ST6003 15x60	M025	50	4,05	54,00	12	0,20	10,25	123
Self-adhesive / Autoadhesivo	M032							



# INDIAN AUTUMN

FS6004

WALL 24" x 48"  
REVESTIMIENTO 61 x 122 cm

48"x96"  
122x244 cm

24"x48"  
61x122 cm

5,9"x23,6"  
15x60 cm

# INDIAN AUTUMN

## FSG6004

WALL 48" x 96"  
REVESTIMIENTO 122 x 244 cm

Due to **Flextone** characteristics, cuts could be done in a simple way to get different sizes and combinations

*Gracias a las características físicas de **Flextone**, es posible realizar cortes de manera sencilla y obtener las medidas deseadas*



48"x96"  
122x244 cm



24"x48"  
61x122 cm



5,9"x23,6"  
15x60 cm

# INDIAN AUTUMN

## FS1004 / FSG1004

WALL 24" x 48" / 48" x 96"

REVESTIMIENTO 61 x 122 cm / 122 x 244 cm

BACKLIT / RETROILUMINADO

48"x96"  
122x244 cm

24"x48"  
61x122 cm



# INDIAN AUTUMN

## ST6004

WALL 5,9" x 23,6"  
REVESTIMIENTO 15 x 60 cm



48"x96"  
122x244 cm

24"x48"  
61x122 cm

5,9"x23,6"  
15x60 cm

# INDIAN AUTUMN

WALL 5,9" x 23,6" / 24" x 48" / 48" x 96"  
 REVESTIMIENTO 15 x 60 / 61 x 122 / 122 x 244 cm



FSG6004 122x244 M011



ST6004 15x60 M025  
M032



FS6004 61x122 M009

ST6004

OPTION A - Original Flextone product for a traditional installation.  
 OPTION B - Flextone product with an adhesive base for a fixation without added materials.

OPCIÓN A - Producto Flextone original para una colocación tradicional.  
 OPCIÓN B - Producto Flextone con una base adhesiva para una fijación sin materiales añadidos.

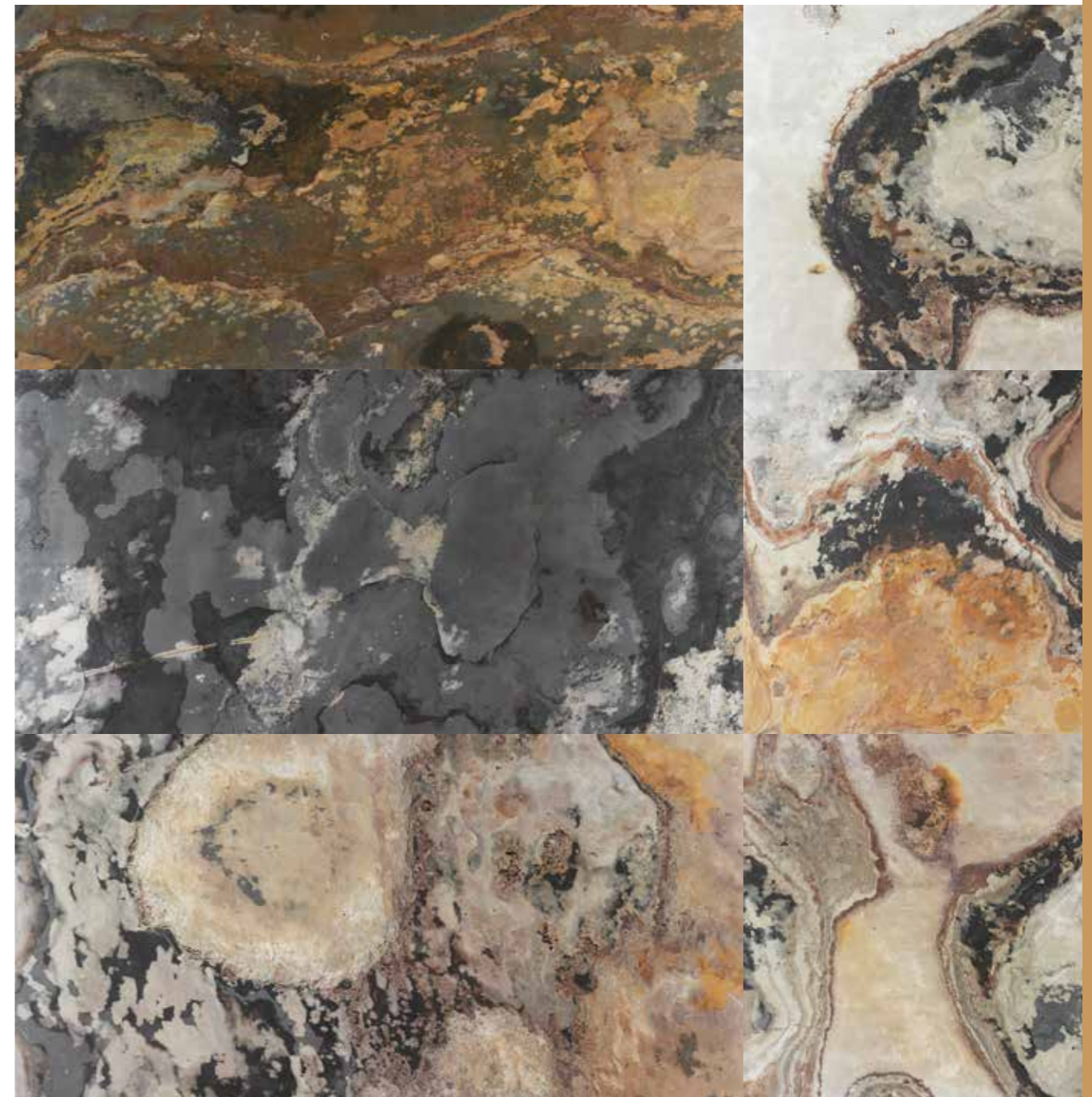

Natural variability of stones / Variabilidad natural de las piezas

	Prize Code	P./Box	SQM/Box	SQM Palet	Box/Palet	Kg/Piece	Kg/Box	Kg/Palet
FSG6004 122x244	M011	1	2,98	223,26	75	5,12	5,12	384,37
FSG1004 122x244 Backlit								
FS6004 61x122	M009	6	4,46	89,28	20	1,48	8,91	178,35
FS1004 61x122 Backlit	M010							
ST6004 15x60	M025	50	4,50	54	12	0,20	10,25	123
Self-adhesive / Autoadhesivo	M032							

# GOLD GREEN

## FS6005

WALL 24" x 48"  
REVESTIMIENTO 61 x 122 cm



48" x 96"  
122 x 244 cm



24" x 48"  
61 x 122 cm



# GOLD GREEN

## FSG6005

WALL 48" x 96"  
REVESTIMIENTO 122 x 244 cm



48"x96"  
122x244 cm



24"x48"  
61x122 cm

# GOLD GREEN

WALL 24" x 48" / 48" x 96"

REVESTIMIENTO 61 x 122 / 122 x 244 cm



**FSG6005** 122x244 M011



**FS6005** 61x122 M009



Natural variability of stones / Variabilidad natural de las piezas

	Prize Code	P./Box	SQM/Box	SQM Palet	Box/Palet	Kg./Piece	Kg./Box	Kg./Palet
<b>FSG6005</b> 122x244	<b>M011</b>	<b>1</b>	<b>2,98</b>	<b>223,26</b>	<b>75</b>	<b>5,12</b>	<b>5,12</b>	<b>384,30</b>
<b>FS6005</b> 61x122	<b>M009</b>	<b>6</b>	<b>4,46</b>	<b>89,28</b>	<b>20</b>	<b>1,48</b>	<b>8,91</b>	<b>178,35</b>



# SILVER GREY

## FS6006

WALL 24" x 48"

REVESTIMIENTO 61 x 122 cm



FS6006 61x122 M009



	Prize Code	P./Box	SQM/Box	SQM Palet	Box/Palet	Kg/Piece	Kg/Box	Kg/Palet
FS6006 61x122	M009	6	4,46	89,28	20	1,48	8,92	178,35

# S. WHITE

## FS6007 / FSG6007

WALL 24" x 48" / 48 x 96"

REVESTIMIENTO 61 x 122 cm / 122 x 244 cm



48"x96"  
122x244 cm



24"x48"  
61x122 cm

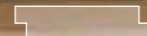

5,9"x23,6"  
15x60 cm

# S. WHITE



## FS 1007 / FSG1007

WALL 24" x 48" / 48" x 96"

REVESTIMIENTO 61 x 122 cm / 122 x 244 cm

BACKLIT / RETROILUMINADO



48"x96"  
122x244 cm

24"x48"  
61x122 cm



# S. WHITE

WALL 5,9" x 23,6" / 24" x 48" / 48" x 96"

REVESTIMIENTO 15 x 60 / 61 x 122 / 122 x 244 cm



FSG6007 122x244 M011



ST6007 15x60 M025  
M032



FS6007 61x122 M009



ST6007

OPTION A - Original Flextone product for a traditional installation.  
OPTION B - Flextone product with an adhesive base for a fixation without added materials.

OPCIÓN A - Producto Flextone original para una colocación tradicional.  
OPCIÓN B - Producto Flextone con una base adhesiva para una fijación sin materiales añadidos.



Natural variability of stones / Variabilidad natural de las piezas

	Prize Code	P./Box	SQM/Box	SQM Palet	Box/Palet	Kg/Piece	Kg/Box	Kg/Palet
FSG6007 122x244	M011	1	2,98	223,26	75	5,12	5,12	384,37
FSG1007 122x244 Backlit								
FS6007 61x122	M009	6	4,46	89,28	20	1,48	8,92	178,35
FS1007 61x122 Backlit	M010							
ST6007 15x60	M025	50	4,50	54	12	0,20	10,25	123
Self-adhesive / Autoadhesivo	M032							

# AUBURN

## FS6008

WALL 24" x 48"  
REVESTIMIENTO 61 x 122 cm



FS6008 61x122 M009

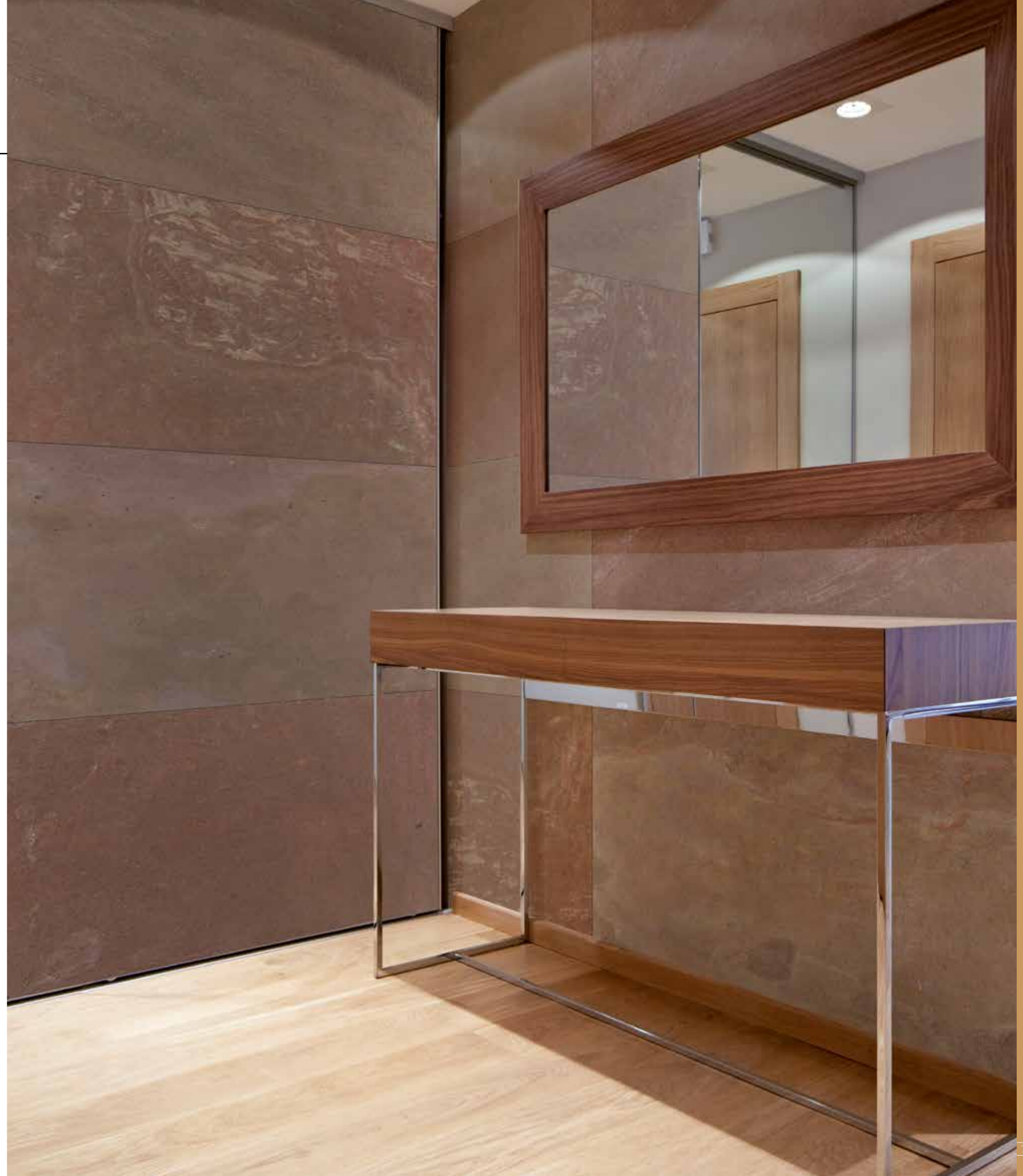

	Prize Code	P./Box	SQM/Box	SQM Palet	Box/Palet	Kg/Piece	Kg/Box	Kg/Palet
FS6008 61x122	M009	6	4,46	89,28	20	1,48	8,91	178,35

# SILVER SHINE

## FS6009

WALL 24" x 48"  
REVESTIMIENTO 61 x 122 cm



48" x 96"  
122 x 244 cm



24" x 48"  
61 x 122 cm

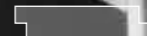

5,9" x 23,6"  
15 x 60 cm

# SILVER SHINE

---

## FSG6009

WALL 48" x 96"  
REVESTIMIENTO 122 x 244 cm

Due to **Flextone** characteristics, cuts could be done in a simple way to get different sizes and combinations

*Gracias a las características físicas de **Flextone**, es posible realizar cortes de manera sencilla y obtener las medidas deseadas*



48"x96"  
122x244 cm



24"x48"  
61x122 cm



5,9"x23,6"  
15x60 cm

# SILVER SHINE

## ST6009

WALL 5,9" x 23,6"  
REVESTIMIENTO 15 x 60 cm

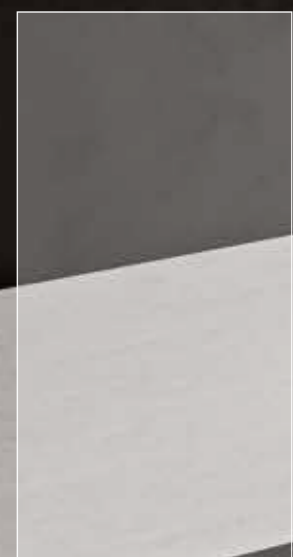

48"x96"  
122x244 cm



24"x48"  
61x122 cm

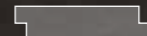

5,9"x23,6"  
15x60 cm



# SILVER SHINE

WALL 5,9" x 23,6" / 24" x 48" / 48" x 96"

REVESTIMIENTO 15 x 60 / 61 x 122 / 122 x 244 cm



FSG6009 122x244 M011



ST6009 15x60 M025  
M032



FS6009 61x122 M009



**ST6009**

OPTION A - Original Flextone product for a traditional installation.  
OPTION B - Flextone product with an adhesive base for a fixation without added materials.

OPCIÓN A - Producto Flextone original para una colocación tradicional.  
OPCIÓN B - Producto Flextone con una base adhesiva para una fijación sin materiales añadidos.



Natural variability of stones / Variabilidad natural de las piezas

	Prize Code	P./Box	SQM/Box	SQM Palet	Box/Palet	Kg/Piece	Kg/Box	Kg/Palet
FSG6009 122x244	M011	1	2,98	223,26	75	5,12	5,12	384,37
FS6009 61x122	M009	6	4,46	89,28	20	1,48	8,92	178,35
ST6009 15x60	M025	50	4,50	54	12	0,20	10,25	123
Self-adhesive / Autoadhesivo	M032							

# AUTUMN RUSTIC

## FS6010

WALL 24" x 48"  
REVESTIMIENTO 61 x 122 cm

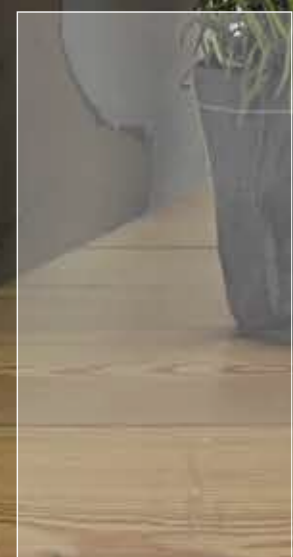

48" x 96"  
122 x 244 cm

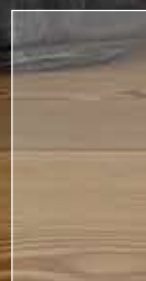

24" x 48"  
61 x 122 cm



5,9" x 23,6"  
15 x 60 cm

# AUTUMN RUSTIC

---

## FSG6010

WALL 48" x 96"  
REVESTIMIENTO 122 x 244 cm



48"x96"  
122x244 cm



24"x48"  
61x122 cm

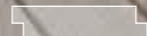

5,9"x23,6"  
15x60 cm

# AUTUMN RUSTIC



## FS1010

WALL 24" x 48"  
REVESTIMIENTO 61 x 122 cm

BACKLIT / RETROILUMINADO



24"x48"  
61x122 cm



# AUTUMN RUSTIC

WALL 5,9" x 23,6" / 24" x 48" / 48" x 96"

REVESTIMIENTO 15 x 60 / 61 x 122 / 122 x 244 cm

BACKLIT / RETROILUMINADO



FSG6010 122x244 M011



ST6010 15x60 M025  
M032



FS6010 61x122 M009



ST6010

OPTION A - Original Flextone product for a traditional installation.  
OPTION B - Flextone product with an adhesive base for a fixation without added materials.

OPCIÓN A - Producto Flextone original para una colocación tradicional.  
OPCIÓN B - Producto Flextone con una base adhesiva para una fijación sin materiales añadidos.



Natural variability of stones / Variabilidad natural de las piezas

	Prize Code	P./Box	SQM/Box	SQM Palet	Box/Palet	Kg/Piece	Kg/Box	Kg/Palet
FSG6010 122x244	M011	1	2,98	223,26	75	5,12	5,12	384,37
FS6010 61x122	M009	6	4,46	89,28	20	1,48	8,91	178,35
FS1010 61x122 Backlit	M010							
ST6010 15x60	M025	50	4,50	54	12	0,20	10,25	123
Self-adhesive / Autoadhesivo	M032							

# DUSK SPRINKLE

## FS6011

WALL 24" x 48"  
REVESTIMIENTO 61 x 122 cm



48" x 96"  
122 x 244 cm

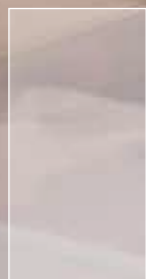

24" x 48"  
61 x 122 cm

# DUSK SPRINKLE

## FSG6015

WALL 48" x 96"  
REVESTIMIENTO 122 x 244 cm



48"x96"  
122x244 cm



24"x48"  
61x122 cm



5,9"x23,6"  
15x60 cm

# DUSK SPRINKLE

WALL 24" x 48" / 48" x 96"

REVESTIMIENTO 61 x 122 / 122 x 244 cm



**FSG6015** 122x244 M011



**FS6011** 61x122 M009



Natural variability of stones / *Variabilidad natural de las piezas*

	Prize Code	P./Box	SQM/Box	SQM Palet	Box/Palet	Kg./Piece	Kg./Box	Kg./Palet
<b>FSG6015</b> 122x244	<b>M011</b>	<b>1</b>	<b>2,98</b>	<b>223,26</b>	<b>75</b>	<b>5,12</b>	<b>5,12</b>	<b>384,37</b>
<b>FS6011</b> 61x122	<b>M009</b>	<b>6</b>	<b>4,46</b>	<b>89,28</b>	<b>20</b>	<b>1,48</b>	<b>8,91</b>	<b>178,35</b>
<b>FS1014</b> 61x122 Backlit	<b>M010</b>	<b>6</b>	<b>4,46</b>	<b>89,28</b>	<b>20</b>	<b>1,48</b>	<b>8,91</b>	<b>178,35</b>



# FOREST

---

## FS6012

WALL 24" x 48"  
REVESTIMIENTO 61 x 122 cm

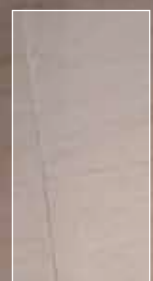

24"x48"  
61x122 cm



5,9"x23,6"  
15x60 cm

# FOREST

## ST6015

WALL 5,9" x 23,6"  
REVESTIMIENTO 15 x 60 cm



24"x48"  
61x122 cm

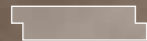

5,9"x23,6"  
15x60 cm

# FOREST

WALL 5,9" x 23,6" / 24" x 48"

REVESTIMIENTO 15 x 60 / 61 x 122 cm



FS6012 61x122 M009



ST6015 15x60 M025  
M032



**ST6015**

OPTION A - Original Flextone product for a traditional installation.  
OPTION B - Flextone product with an adhesive base for a fixation without added materials.

OPCIÓN A - Producto Flextone original para una colocación tradicional.  
OPCIÓN B - Producto Flextone con una base adhesiva para una fijación sin materiales añadidos.



Natural variability of stones / Variabilidad natural de las piezas

	Prize Code	P./Box	SQM/Box	SQM Palet	Box/Palet	Kg/Piece	Kg/Box	Kg/Palet
FS6012 61x122	M009	6	4,46	89,28	20	1,45	8,92	178,35
ST6015 15x60	M025	50	4,50	54	12	0,20	10,50	123
Self-adhesive / Autoadhesivo	M032							

# RAIN FOREST GREEN

## ST6032

WALL 5,9" x 23,6"

REVESTIMIENTO 15 x 60 cm

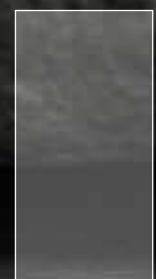

24"x48"  
61x122 cm



5,9"x23,6"  
15x60 cm

# RAIN FOREST BROWN

## FS6033

WALL 24" x 48"  
REVESTIMIENTO 61 x 122 cm



24" x 48"  
61 x 122 cm

5,9" x 23,6"  
15 x 60 cm

# RAIN FOREST

WALL 5,9" x 23,6" / 24" x 48"

REVESTIMIENTO 15 x 60 / 61 x 122 cm

**ST6032 - ST6033**

OPTION A - Original Flextone product for a traditional installation.  
OPTION B - Flextone product with an adhesive base for a fixation without added materials.

OPCIÓN A - Producto Flextone original para una colocación tradicional.  
OPCIÓN B - Producto Flextone con una base adhesiva para una fijación sin materiales añadidos.





**FS6032 GREEN**   
61x122 M009





**FS6033 BROWN**   
61x122 M009



**ST6032 GREEN** 15x60 M025   
M032 



**ST6033 BROWN** 15x60 M025   
M032 



Natural variability of stones / Variabilidad natural de las piezas

	Prize Code	P./Box	SQM/Box	SQM Palet	Box/Palet	Kg/Piece	Kg/Box	Kg/Palet
<b>FS6032</b> 61x122	<b>M009</b>	<b>6</b>	<b>4,46</b>	<b>89,28</b>	<b>20</b>	<b>1,48</b>	<b>8,91</b>	<b>178,35</b>
<b>FS6033</b> 61x122								
<b>ST6032</b> 15x60	<b>M025</b>	<b>40</b>	<b>3,60</b>	<b>54</b>	<b>15</b>	<b>0,20</b>	<b>8,20</b>	<b>123</b>
<b>ST6033</b> 15x60								
Self-adhesive / Autoadhesivo	<b>M032</b>							

# TEAK WOOD

## FS6041

WALL 24" x 48"  
REVESTIMIENTO 61 x 122 cm

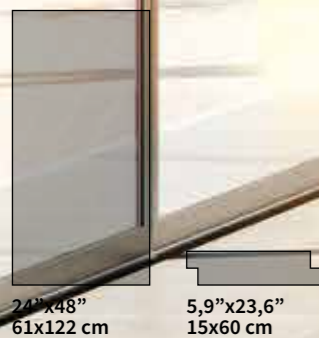

24" x 48"  
61 x 122 cm

5,9" x 23,6"  
15 x 60 cm

# TEAK WOOD

## ST6041

WALL 5,9" x 23,6"  
REVESTIMIENTO 15 x 60 cm



24"x48"  
61x122 cm

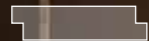

5,9"x23,6"  
15x60 cm



# TEAK WOOD

**WALL** 5,9" x 23,6" / 24" x 48"

**REVESTIMIENTO** 15 x 60 / 61 x 122 cm



**FS6041** 61x122 M007



**ST6041** 15x60 M025  
M032



**ST6041**

OPTION A - Original Flextone product for a traditional installation.  
OPTION B - Flextone product with an adhesive base for a fixation without added materials.

OPCIÓN A - Producto Flextone original para una colocación tradicional.  
OPCIÓN B - Producto Flextone con una base adhesiva para una fijación sin materiales añadidos.



Natural variability of stones / Variabilidad natural de las piezas

	Prize Code	P./Box	SQM/Box	SQM Palet	Box/Palet	Kg/Piece	Kg/Box	Kg/Palet
<b>FS6041</b> 61x122	<b>M007</b>	<b>6</b>	<b>4,46</b>	<b>89,28</b>	<b>20</b>	<b>1,48</b>	<b>8,92</b>	<b>178,35</b>
<b>ST6041</b> 15x60	<b>M025</b>	<b>40</b>	<b>3,60</b>	<b>54</b>	<b>15</b>	<b>0,20</b>	<b>8,20</b>	<b>123</b>
Self-adhesive / Autoadhesivo	<b>M032</b>							

# CONCRET

CONCRET

114

**Concret** collection, with concrete finish, features natural isolation, endurance, fire proof, and more. These thin coating layers can be placed in any surface, both indoor and outdoors, and features a protective water proof coating.

Features: 1-2 mm thick / Light and flexible / Fiber glass and polyester coating / Resistance, endurance, dimensional stability.

*La gama **Concret**, en acabado cemento, cuenta con múltiples propiedades, como el aislamiento natural, la duración o la resistencia al fuego. Estas láminas finas y ligeras se adaptan a cualquier tipo de superficie, ya sea en interior o en exterior, ya que cuentan con una capa de impermeabilización que actúa como protector.*

*Características: 1 a 2 mm. de espesor / Flexible y ligera / Recubierta de fibra de vidrio y poliéster / Resistente, duradera y estabilidad dimensional.*

CERAMICTOUCH  
View it with 



# CONCRET

WALL 23,6" x 48" / 48" x 102,3"

REVESTIMIENTO 60 x 122 cm / 122 x 260 cm



# CONCRET

WALL 23,6" x 48" / 48" x 102,3"

REVESTIMIENTO 60 x 122 cm / 122 x 260 cm



CONCRET WHITE 122 x 260 M038 / 60 x 122 M039 



CONCRET DARK 122 x 260 M038 / 60 x 122 M039 



CONCRET LIGHT GREY 122 x 260 M038 / 60 x 122 M039 



	Prize Code	P./Box	SQM/Box	SQM Palet	Box/Palet	Kg/Piece	Kg/Box	Kg/Palet
Concret 120x260	M038	10	31,75	253,97	8	12,50	125	1.000
Concret 60x122	M039	6	4,39	87,80	20	2	12	240

# THE STONES

CORALINA	120	ST14WB	160
TRAVERTINO	126	ST18WB	162
1961 PIZARRA MULT.	134	ST61WB	164
ARDOSIA	136	ST300	166
SILVER GREY	138	ST303	168
GOLD GREEN	140	ST304	170
TEKA	142	ST305	172
ST14BZ	144	ST306	174
ST20BZ	146	ST	176
ST29	148	ST50	178
ST31	150	ST51	178
ST40W	152	ST52	178
ST41	154	GOLD GREEN ST301	179
ST56	156	COOPER ST302	179
ST61BZ	158	COOPER PULIDO	179

Natural stones to decorate your place. Stone is the oldest material used in construction reviving now with new applications to follow the new trends. Meet our full range of finishes, colors and formats.

*Piedras naturales para decorar tus espacios. La piedra es el material más antiguo en la construcción que resurge con nuevas aplicaciones adaptándose a los nuevos tiempos. Conoce toda nuestra completa gama de acabados, colores y formatos.*

CERAMICTOUCH   
View it with



# CORALINA

FLOOR 24" x 16" THICKNESS 0,8"  
PAVIMENTO 40,6 x 61 ESPESOR 2 cm

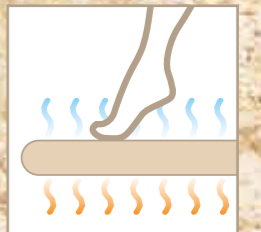

# CORALINA

FLOOR 24" x 16" THICKNESS 0,8"  
PAVIMENTO 40,6 x 61 ESPESOR 2 cm

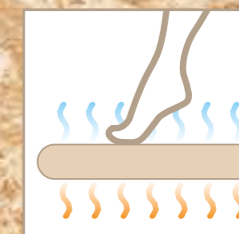

# CORALINA

FLOOR 24" x 16" THICKNESS 0,8"  
PAVIMENTO 40,6 x 61 ESPESOR 2 cm

**BORDILLO CORALINA CLÁSICA**  
30,5x61x4,5 P078  
!



**LOSA CORALINA CLÁSICA**  
40,6x61x2 M003  
!



**LOSA CORALINA CLÁSICA ESTUCADA**  
40,6x61x2 M008  
!



Las características físicas de las piedras de la serie **Coralina** hacen que el calor del sol sea absorbido, de forma que su superficie permanezca siempre agradable y fresca

The physical features of the stones in the **Coralina** series ensure that the sun's heat is absorbed, so that the surface always remains pleasant and cool.



**PIRAMIDE CORALINA**  
32x32 P077  
!



**REJILLA CORALINA**  
32x32 P076  
!



**TRAVERTINO ALFA PULIDO**  
30x30 P075  
!



	Prize Code	P/Box	SQM/Box	SQM Palet	Box/Palet	Kg/Piece	Kg/Box	Kg/Palet
<b>Coralina Bordillo</b> 30,5x61x4,5	<b>P078</b>	<b>1</b>	<b>0,186</b>	<b>6,324</b>	<b>34</b>	<b>5,10</b>	<b>5,10</b>	<b>173,40</b>
<b>Coralina Losa Clásica</b> 40,6x61x2	<b>M003</b>	<b>3</b>	<b>0,740</b>	<b>23,324</b>	<b>32</b>	<b>5,10</b>	<b>15,30</b>	<b>489,60</b>
<b>Coralina Losa Clásica Est.</b> 40,6x61x2	<b>M008</b>	<b>3</b>	<b>0,740</b>	<b>23,324</b>	<b>32</b>	<b>5,10</b>	<b>15,30</b>	<b>489,60</b>
<b>Coralina Pirámide</b> 32x32	<b>P077</b>	<b>7</b>	<b>0,720</b>	<b>38,710</b>	<b>54</b>	<b>1,65</b>	<b>11,55</b>	<b>623,70</b>
<b>Coralina Rejilla</b> 22,5x30	<b>P076</b>	<b>5</b>	<b>0,337</b>	<b>18,220</b>	<b>54</b>	<b>1,65</b>	<b>8,25</b>	<b>445,50</b>
<b>Travertino Alfa Pulido</b> 30x30	<b>P075</b>	<b>12</b>	<b>1,080</b>	<b>45,360</b>	<b>42</b>	<b>1,65</b>	<b>19,80</b>	<b>831,60</b>



# TRAVERTINO NOCE

FLOOR 8" x 8" / 8" x 16" / 16" x 16" / 24" x 16" THICKNESS 0,5"

PAVIMENTO 20,3 x 20,3 / 20,3 x 40,6 / 40,6 x 40,6 / 40,6 x 61 cm ESPESOR 1,2 cm



# TRAVERTINO SILVER

FLOOR 8" x 8" / 8" x 16" / 16" x 16" / 24" x 16" THICKNESS 0,5"

PAVIMENTO 20,3 x 20,3 / 20,3 x 40,6 / 40,6 x 40,6 / 40,6 x 61 cm ESPESOR 1,2 cm

# TRAVERTINO

FLOOR 8" x 8" / 8" x 16" / 16" x 16" / 24" x 16" THICKNESS 0,5"

PAVIMENTO 20,3 x 20,3 / 20,3 x 40,6 / 40,6 x 40,6 / 40,6 x 61 cm ESPESOR 1,2 cm



**NOCE**  
40,6x61 M027  
☞☞



**NOCE**  
40,6x40,6 M027  
☞☞



**NOCE**  
20,3x40,6 M028  
☞☞



**NOCE**  
20,3x20,3 M028  
☞☞



**SILVER**  
40,6x61 M007  
☞☞



**SILVER**  
40,6x40,6 M007  
☞☞



**SILVER**  
20,3x40,6 M029  
☞☞



**SILVER**  
20,3x20,3 M027  
☞☞



**SILVER LATTE**  
40,6x61 M002  
☞☞



**SILVER LATTE**  
40,6x40,6 M002  
☞☞



**SILVER LATTE**  
20,3x40,6 M030  
☞☞



**SILVER LATTE**  
20,3x20,3 M031  
☞☞

	Prize Code	P./Box	SQM/Box	SQM Palet	Box/Palet	Kg/Piece	Kg/Box	Kg/Palet
Travertino 40,6x61x1,2	M027 - M007 - M002	4	0,99	39,64	40	7,30	29,20	1.168
Travertino 40,6x40,6x1,2	M027 - M007 - M002	5	0,82	32,96	40	5,10	25,50	1.020
Travertino 20,3x40,6x1,2	M028 - M029 - M030	10	0,82	32,96	40	2,05	20,50	820
Travertino 20,3x20,3x1,2	M028 - M027 - M031	20	0,82	32,96	40	1,2	24	960

# TRAVERTINO

**FLOOR** 8" x 8" / 8" x 16" / 16" x 16" / 24" x 16" **THICKNESS 0,5"**  
**PAVIMENTO** 20,3 x 20,3 / 20,3 x 40,6 / 40,6 x 40,6 / 40,6 x 61 cm **ESPEJOR 1,2 cm**

The multiformat floor allows the use of different modulations and multiple aesthetic solutions. Know how many pieces of each size do you need for your space with the Anjasora simulator.



*El pavimento multiformato permite el uso de diferentes modulaciones y múltiples soluciones estéticas. Sepa cuántas piezas de cada tamaño necesita para su espacio con el Panelador de metros de Anjasora.*

<https://panelador.anjasora.com>

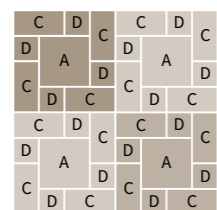
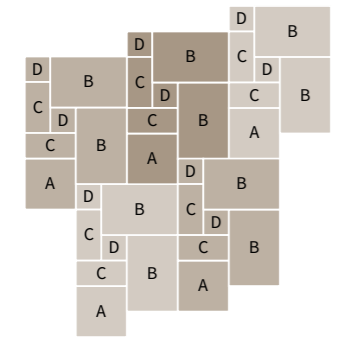
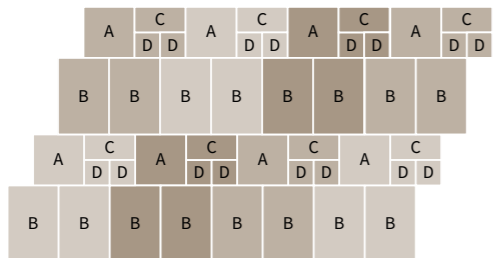
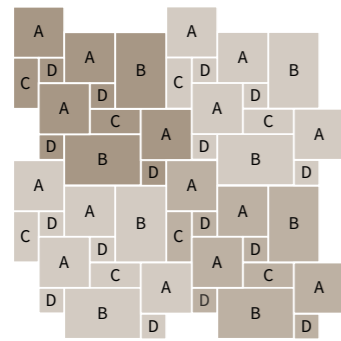
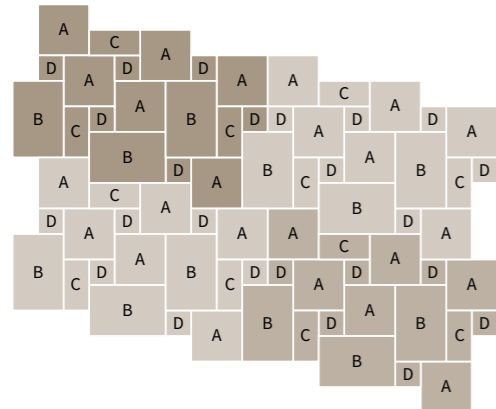

# 1961 PIZARRA MULTICOLOR

FLOOR / WALL 11,8" x 23,6"

PAVIMENTO / REVESTIMIENTO 30 x 60 cm



**1961 PIZARRA  
MULTICOLOR**

30x60 M005

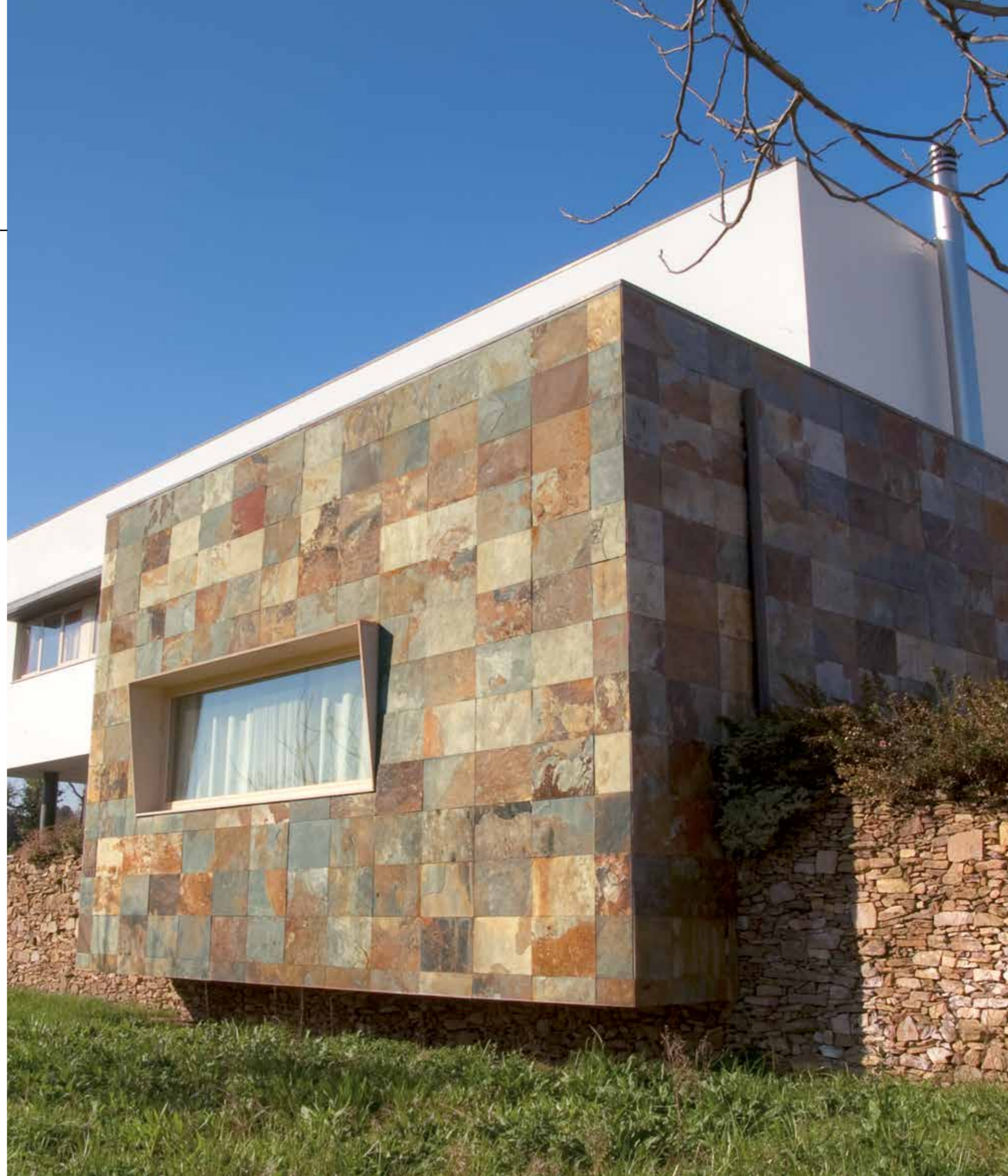

	Prize Code	P./Box	SQM/Box	SQM Palet	Box/Palet	Kg./Piece	Kg./Box	Kg./Palet
1961 Pizarra Multicolor 30x60	M005	5	0,90	32,40	36	5,64	28,20	1.015,20

# ARDOSIA

FLOOR / WALL 11,8" x 23,6"

PAVIMENTO / REVESTIMIENTO 30 x 60 cm



**ARDOSIA  
NEGRA**

30x60 M006



**ARDOSIA  
CINZA**

30x60 M006



**ARDOSIA  
MULTICOLOR**

30x60 M014



	Prize Code	P./Box	SQM/Box	SQM Palet	Box/Palet	Kg/Piece	Kg/Box	Kg/Palet
<b>Ardosia Negra</b> 30x60	<b>M006</b>	<b>5</b>	<b>0,90</b>	<b>50,40</b>	<b>56</b>	<b>4,46</b>	<b>22,30</b>	<b>1.249</b>
<b>Ardosia Cinza</b> 30x60								
<b>Ardosia Multicolor</b> 30x60	<b>M014</b>	<b>5</b>	<b>0,90</b>	<b>28,80</b>	<b>32</b>	<b>4,46</b>	<b>22,30</b>	<b>713,60</b>

# SILVER GREY

FLOOR / WALL 11,8" x 23,6"

PAVIMENTO / REVESTIMIENTO 30 x 60 cm



**SILVER GREY  
CEPILLADO**

30x60 M007



**SILVER GREY  
PULIDO**

30x60 M019

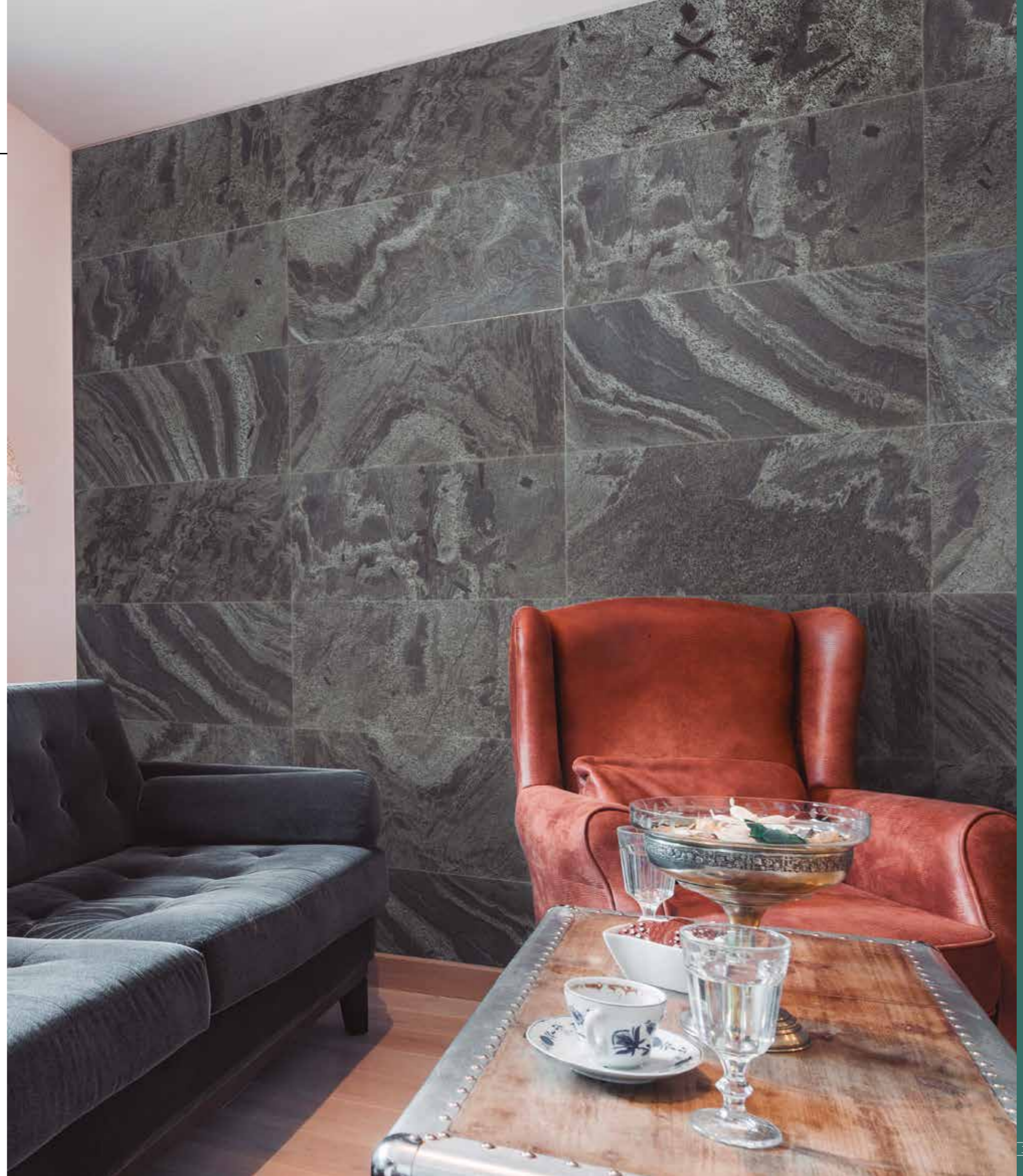

	Prize Code	P./Box	SQM/Box	SQM Palet	Box/Palet	Kg/Piece	Kg/Box	Kg/Palet
Silver Grey Cepillado 30x60	M007	6	1,08	25,92	24	5,63	33,82	811,80
Silver Grey Pulido 30x60	M019							

# GOLD GREEN

FLOOR / WALL 11,8" x 23,6"

PAVIMENTO / REVESTIMIENTO 30 x 60 cm



**GOLD GREEN  
CEPILLADO**

30x60 M007



**GOLD GREEN  
PULIDO**

30x60 M019

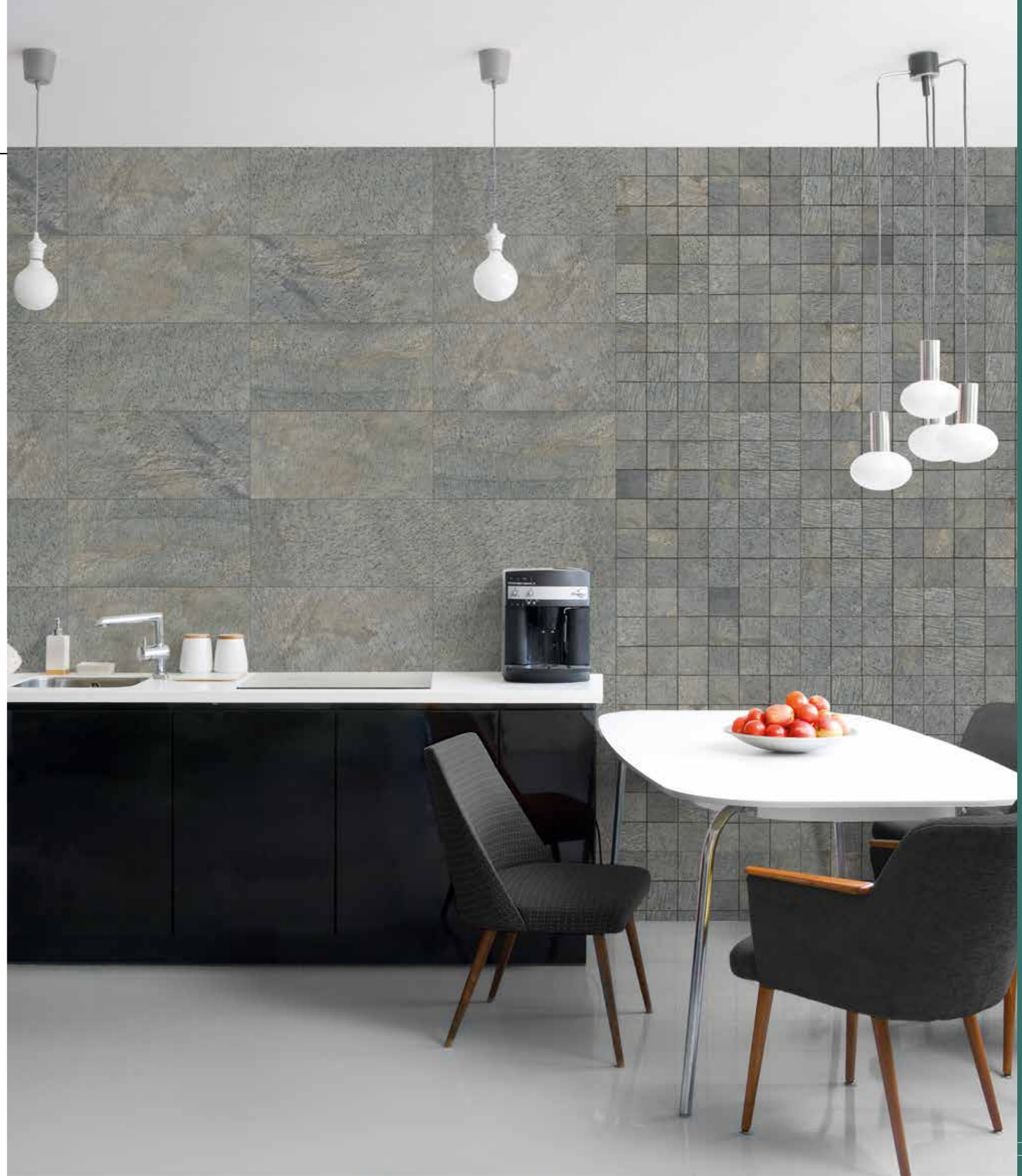

	Prize Code	P./Box	SQM/Box	SQM Palet	Box/Palet	Kg./Piece	Kg/Box	Kg/Palet
Gold Green Cepillado 30x60	M007	5	0,90	32,40	36	4,46	28,20	1.184
Gold Green Pulido 30x60	M019							



# TEKA

FLOOR / WALL 11,8" x 23,6"

PAVIMENTO / REVESTIMIENTO 30 x 60 cm



**TEKA WOOD  
PULIDO**

30x60 M007



	Prize Code	P./Box	SQM/Box	SQM Palet	Box/Palet	Kg/Piece	Kg/Box	Kg/Palet
Teka Wood Pulido 30x60	M007	6	1,08	25,92	24	4,46	26,76	642,24

# ST14BZ

WALL 7" x 13,8"  
 REVESTIMIENTO 18 x 35 cm



**ST14BZ**  
 18x35 M002



**CANTONERA ST14BZ**  
 18x22\* / 18x18\* M004

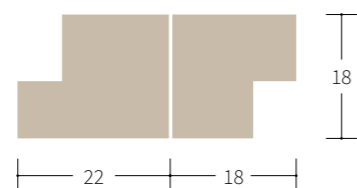

	Prize Code	P./Box	SQM/Box	SQM Palet	Box/Palet	Kg/Piece	Kg/Box	Kg/Palet
ST14BZ 18x35	M002							
CANTONERA ST14BZ 18x22 / 18x18	M004	5	0,31	22,05	70	3,90	19,50	1.365

\* Each corner piece is served in 2 separate pieces *Cada cantonera se sirve en 2 piezas separadas*

# ST20BZ

WALL 7" x 13,8"  
 REVESTIMIENTO 18 x 35 cm



**ST20BZ**  
 18x35 M002

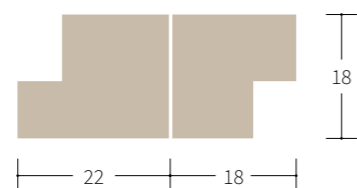

**CANTONERA ST20BZ**  
 18x22\* / 18x18\* M004

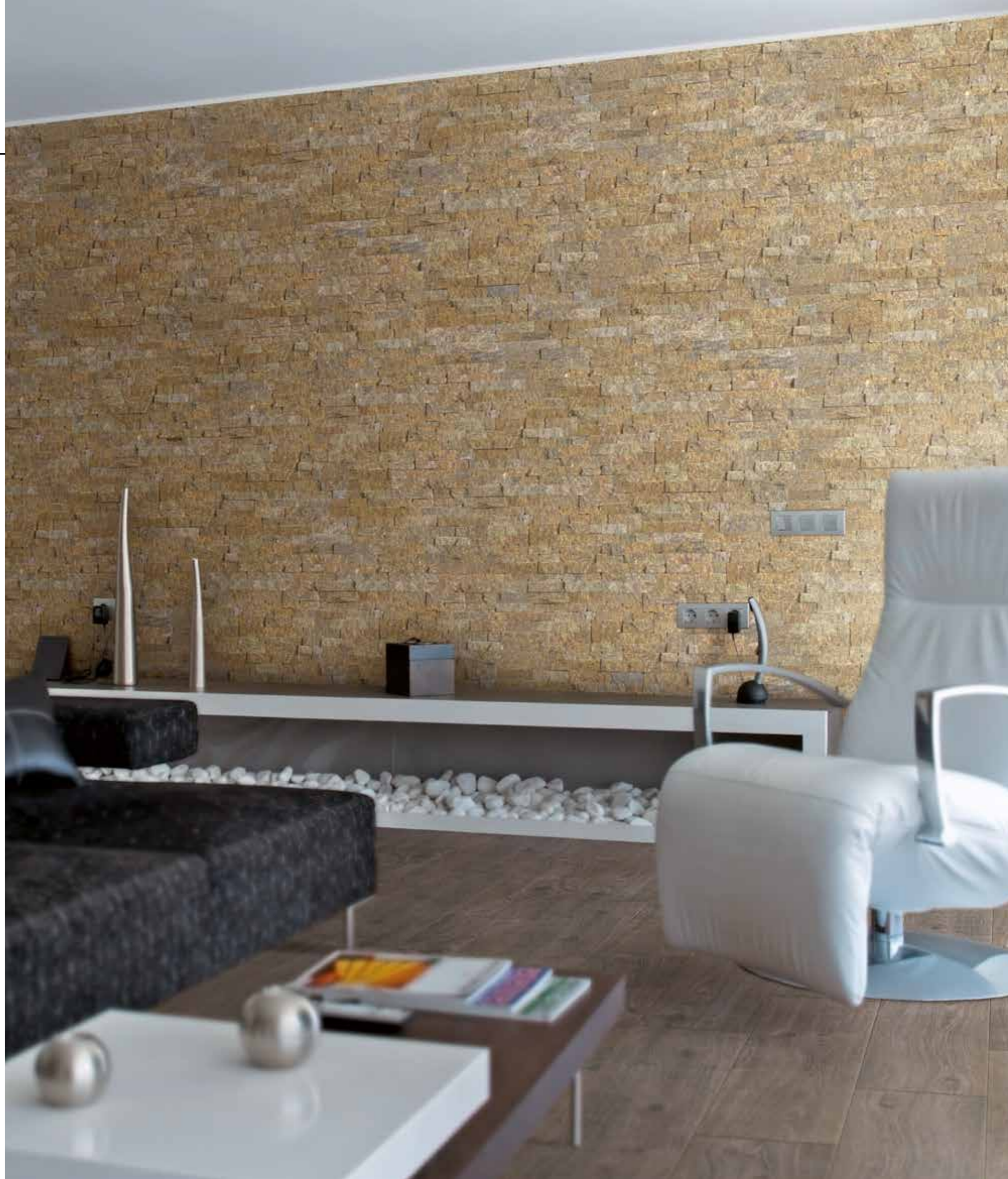

	Prize Code	P./Box	SQM/Box	SQM Palet	Box/Palet	Kg/Piece	Kg/Box	Kg/Palet
ST20BZ 18x35	M002	7	0,44	30,87	70	2,38	15,68	1.167,60
CANTONERA ST20BZ 18x22 / 18x18	M004							

\* Each corner piece is served in 2 separate pieces *Cada cantonera se sirve en 2 piezas separadas*

# ST29

WALL 7" x 13,8"  
REVESTIMIENTO 18 x 35 cm



**ST29**  
18x35 M001



**CANTONERA ST29**  
18x22\* / 18x18\* M003

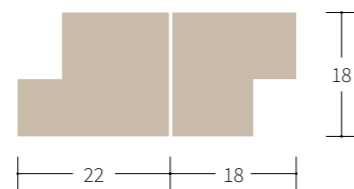

	Prize Code	P./Box	SQM/Box	SQM Palet	Box/Palet	Kg/Piece	Kg/Box	Kg/Palet
ST29 18x35	M001	10	0,63	44,10	70	1,52	15,20	1.064
CANTONERA ST29 18x22 / 18x18	M003							

\* Each corner piece is served in 2 separate pieces *Cada cantonera se sirve en 2 piezas separadas*



# ST31

WALL 7" x 13,8"  
 REVESTIMIENTO 18 x 35 cm



**ST31**  
 18x35 M001



**CANTONERA ST31**  
 18x22\* / 18x18\* M003

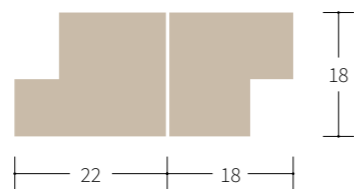

	Prize Code	P./Box	SQM/Box	SQM Palet	Box/Palet	Kg/Piece	Kg/Box	Kg/Palet
ST31 18x35	M001	10	0,63	44,10	70	1,52	15,20	1.064
CANTONERA ST31 18x22 / 18x18	M003							

\* Each corner piece is served in 2 separate pieces *Cada cantonera se sirve en 2 piezas separadas*



# ST40W

WALL 5,9" x 21,6"

REVESTIMIENTO 15 x 55 cm



**ST40W**  
15x55 M002



**CANTONERA ST40W**  
15x37\* / 15x23\* M004

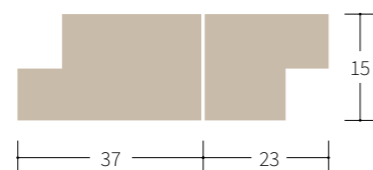

	Prize Code	P./Box	SQM/Box	SQM Palet	Box/Palet	Kg/Piece	Kg/Box	Kg/Palet
<b>ST40W 15x55</b>	<b>M002</b>							
<b>CANTONERA ST40W 15x37 / 15x23</b>	<b>M004</b>	7	0,57	22,72	48	3,30	23,10	1.108,80

\* Each corner piece is served in 2 separate pieces *Cada cantonera se sirve en 2 piezas separadas*



# ST41

WALL 5,9" x 23,6"  
 REVESTIMIENTO 15 x 60 cm



**ST41**  
 15x60 M010



**CANTONERA ST41**  
 15x39\* / 15x26\* M004

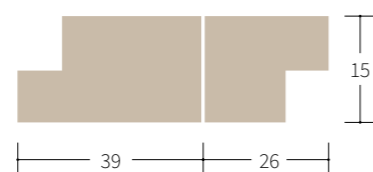

	Prize Code	P./Box	SQM/Box	SQM Palet	Box/Palet	Kg/Piece	Kg/Box	Kg/Palet
<b>ST41</b> 15x60	<b>M010</b>	6	0,54	22,68	42	2,85	17,20	722,40
<b>CANTONERA ST41</b> 15x39 / 15x26	<b>M004</b>							

\* Each corner piece is served in 2 separate pieces *Cada cantonera se sirve en 2 piezas separadas*



# ST56

WALL 7" x 13,8"  
 REVESTIMIENTO 18 x 35 cm



**ST56**  
 18x35 M040



**CANTONERA ST56**  
 18x22\* / 18x18\* M003

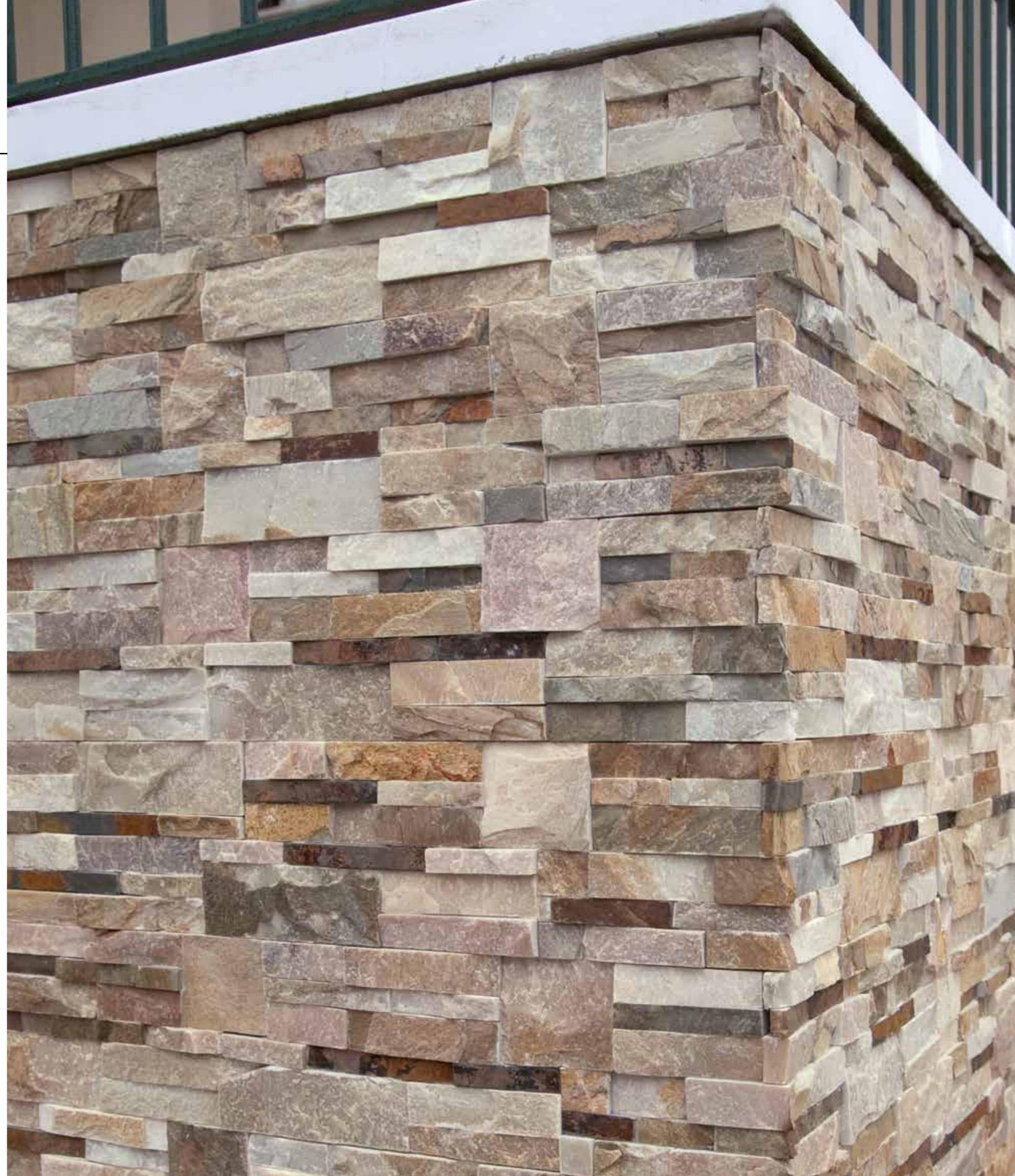
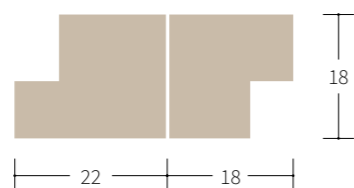

	Prize Code	P./Box	SQM/Box	SQM Palet	Box/Palet	Kg/Piece	Kg/Box	Kg/Palet
ST56 18x35	M001	7	0,44	30,87	70	2,30	16,10	1.127
CANTONERA ST56 18x22 / 18x18	M003							

\* Each corner piece is served in 2 separate pieces *Cada cantonera se sirve en 2 piezas separadas*



# ST61BZ

WALL 7" x 13,8"

REVESTIMIENTO 18 x 35 cm



**ST61BZ**  
18x35 M002



**CANTONERA ST61BZ**   
18x22\* / 18x18\* M004

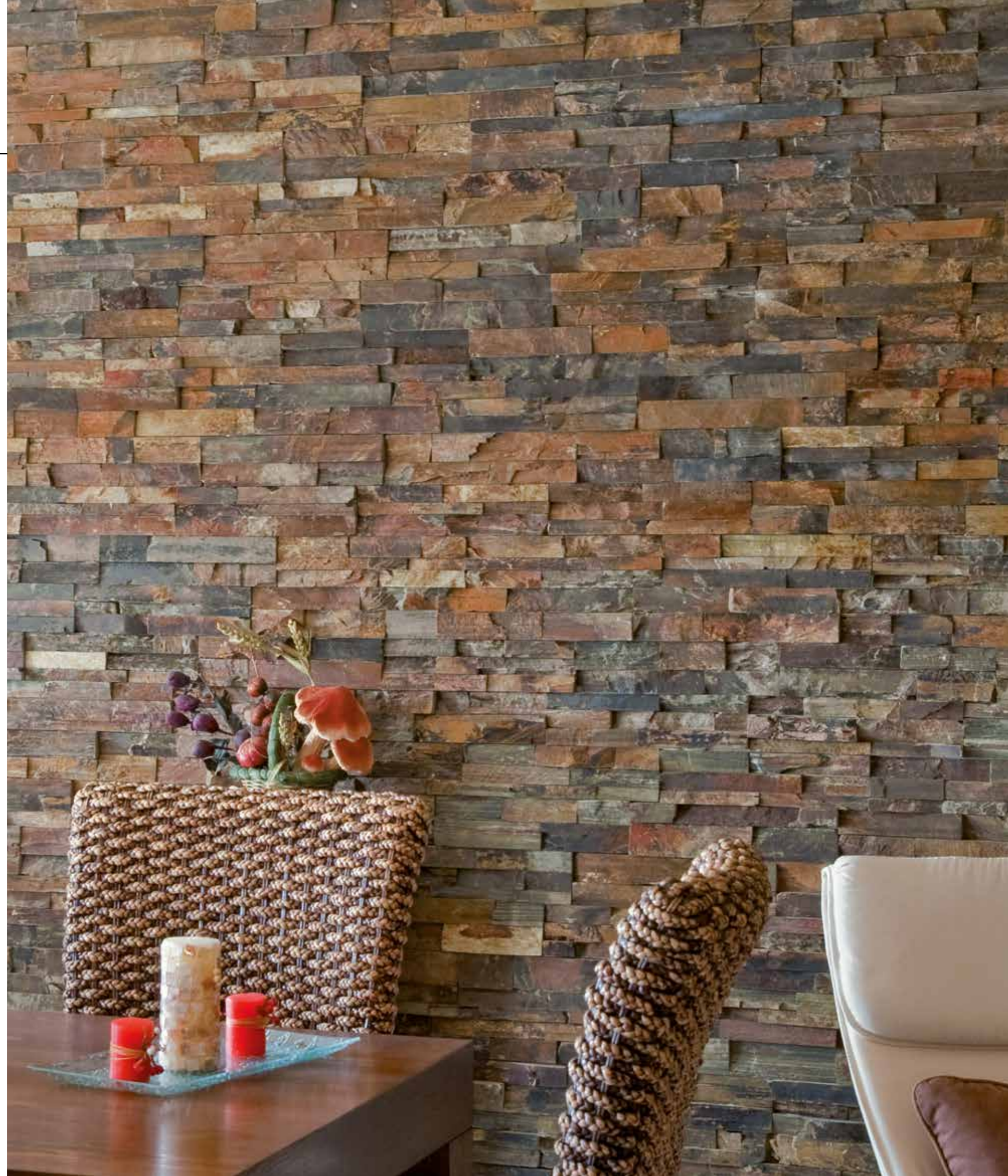
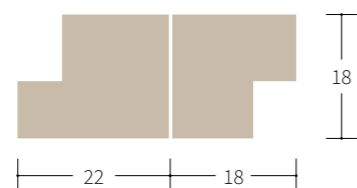

	Prize Code	P./Box	SQM/Box	SQM Palet	Box/Palet	Kg/Piece	Kg/Box	Kg/Palet
ST61BZ 18x35	M002							
		5	0,31	22,05	70	3,90	19,50	1.365
CANTONERA ST61BZ 18x22 / 18x18	M004							

\* Each corner piece is served in 2 separate pieces *Cada cantonera se sirve en 2 piezas separadas*

# ST14WB

WALL 5,9" x 21,6"  
 REVESTIMIENTO 15 x 55 cm



**ST14WB**  
 15x55 M002



**CANTONERA ST14WB**  
 15x37\* / 15x23\* M004

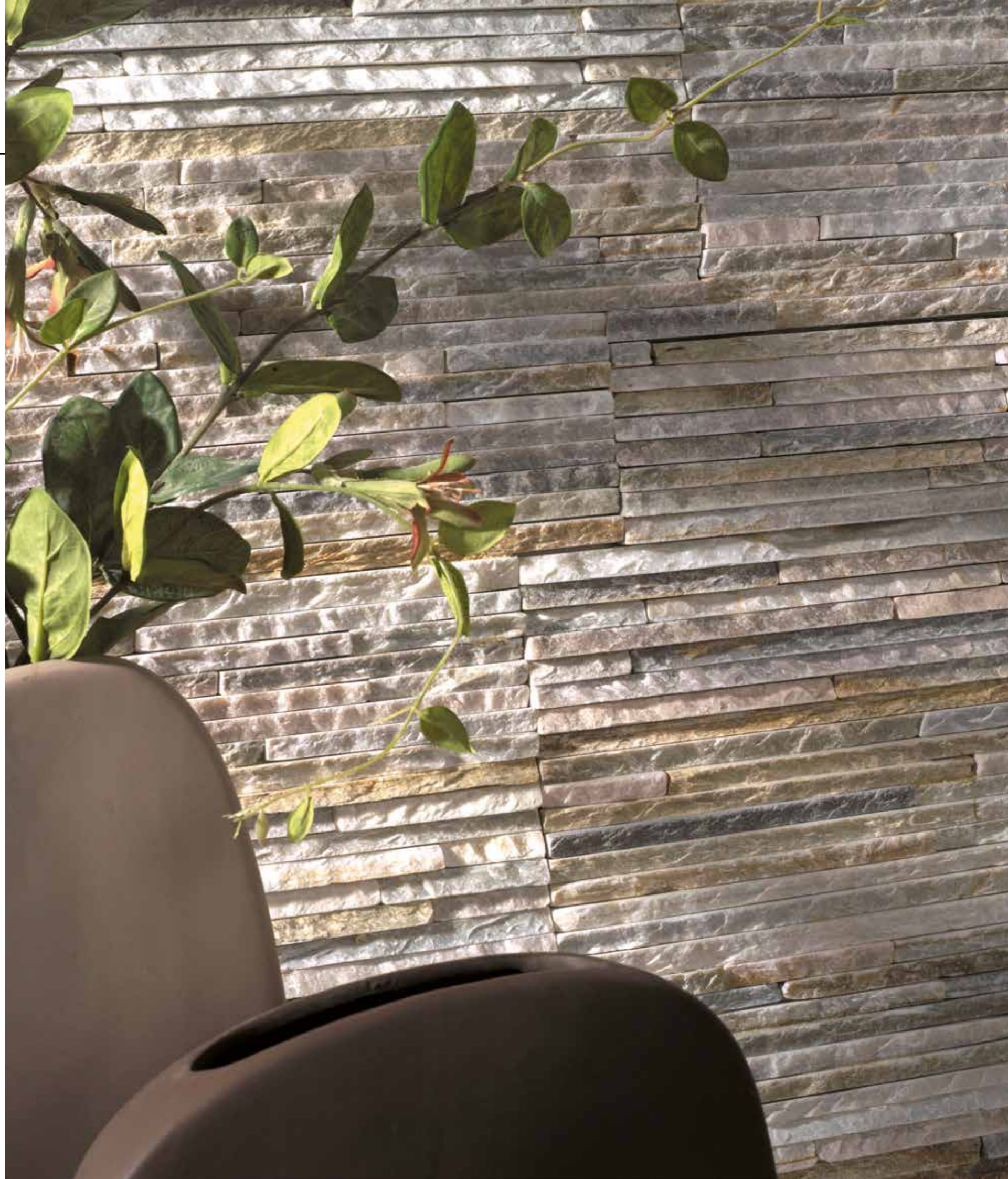
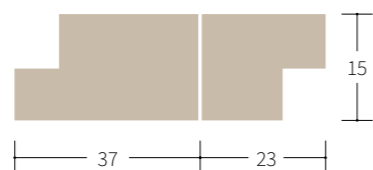

	Prize Code	P./Box	SQM/Box	SQM Palet	Box/Palet	Kg./Piece	Kg./Box	Kg./Palet
<b>ST14WB</b> 15x55	<b>M002</b>	7	0,57	22,72	48	3,30	23,10	1.108,80
<b>CANTONERA ST14WB</b> 15x37 / 15x23	<b>M004</b>							

\* Each corner piece is served in 2 separate pieces *Cada cantonera se sirve en 2 piezas separadas*

# ST18WB

WALL 5,9" x 21,6"  
 REVESTIMIENTO 15 x 55 cm



**ST18WB**  
 15x55 M002



**CANTONERA ST18WB**  
 15x37\* / 15x23\* M004

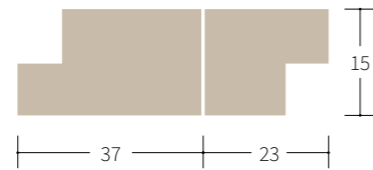

	Prize Code	P./Box	SQM/Box	SQM Palet	Box/Palet	Kg./Piece	Kg/Box	Kg/Palet
<b>ST18WB</b> 15x55	<b>M002</b>							
<b>CANTONERA ST18WB</b> 15x37 / 15x23	<b>M004</b>	7	0,57	22,72	48	3,30	23,10	1.108,80

\* Each corner piece is served in 2 separate pieces *Cada cantonera se sirve en 2 piezas separadas*

# ST61WB

WALL 5,9" x 21,6"  
 REVESTIMIENTO 15 x 55 cm



**ST61WB**  
 15x55 M002



**CANTONERA ST61WB**  
 15x37\* / 15x23\* M004

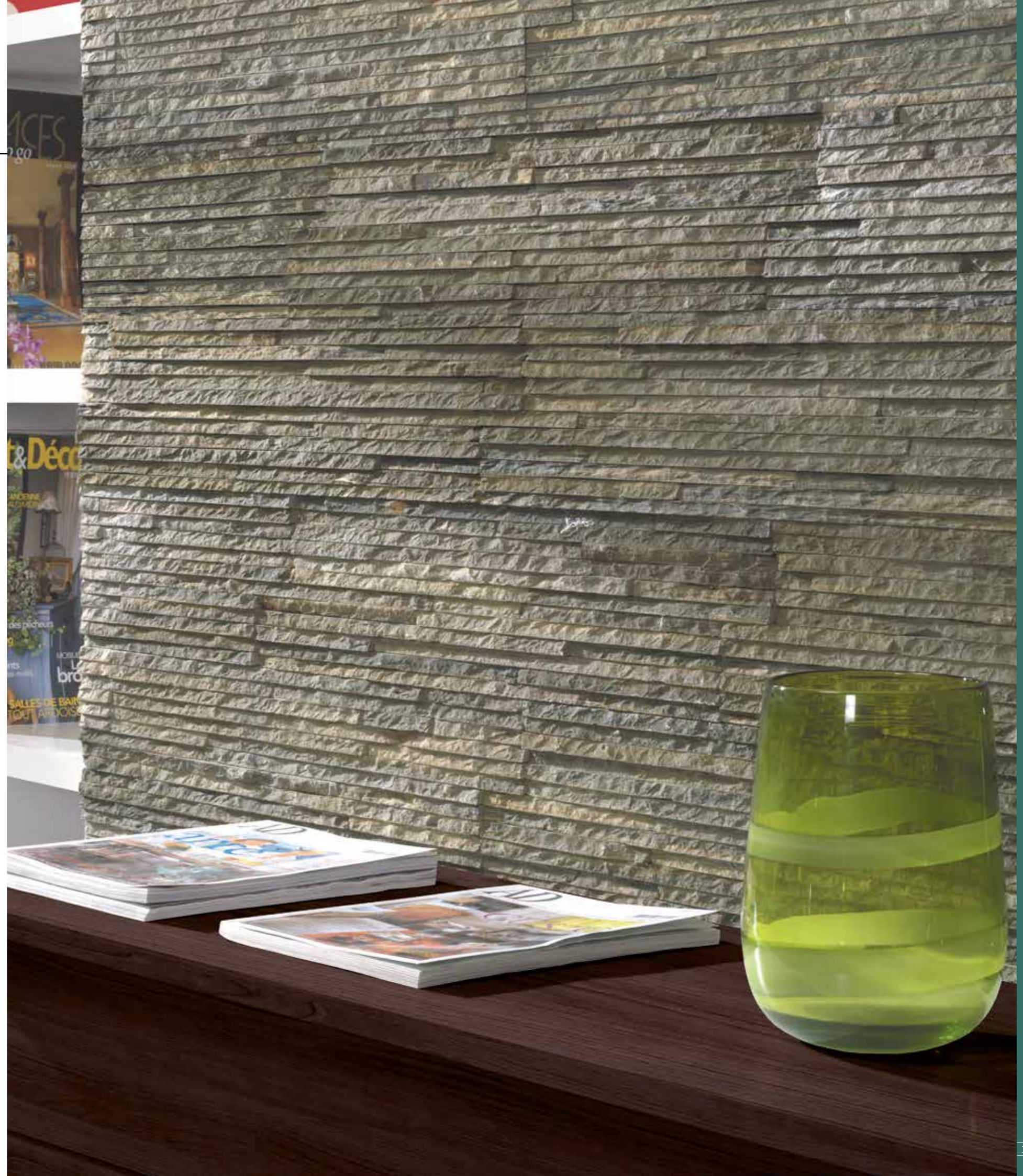
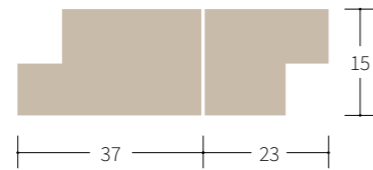

	Prize Code	P./Box	SQM/Box	SQM Palet	Box/Palet	Kg./Piece	Kg/Box	Kg/Palet
<b>ST61WB</b> 15x55	<b>M002</b>							
<b>CANTONERA ST61WB</b> 15x37 / 15x23	<b>M004</b>	7	0,57	22,72	48	3,30	23,10	1.108,80

\* Each corner piece is served in 2 separate pieces *Cada cantonera se sirve en 2 piezas separadas*

# ST300

WALL 5,9" x 23,6"  
 REVESTIMIENTO 15 x 60 cm



**SILVER GREY ST300**  
 15x60 M019



**CANTONERA ST300**  
 15x39\* / 15x26\* M020

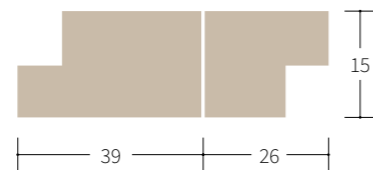

	Prize Code	P./Box	SQM/Box	SQM Palet	Box/Palet	Kg/Piece	Kg/Box	Kg/Palet
Silver Grey ST300 15x60	M019							
CANTONERA ST300 15x39 / 15x26	M020	6	0,54	22,68	42	2,35	14,45	595

\* Each corner piece is served in 2 separate pieces *Cada cantonera se sirve en 2 piezas separadas*



# ST303

WALL 5,9" x 23,6"  
 REVESTIMIENTO 15 x 60 cm



**SILVER SHINE ST303**  
 15x60 M019



**CANTONERA ST303**  
 15x39\* / 15x26\* M020

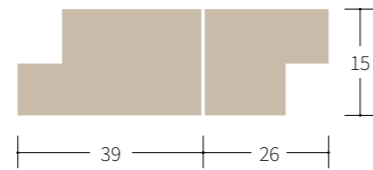

	Prize Code	P./Box	SQM/Box	SQM Palet	Box/Palet	Kg/Piece	Kg/Box	Kg/Palet
Silver Shine ST303 15x60	M019	6	0,54	22,68	42	3,20	19,20	806,40
CANTONERA ST303 15x39 / 15x26	M020							

\* Each corner piece is served in 2 separate pieces *Cada cantonera se sirve en 2 piezas separadas*

# ST304

WALL 5,9" x 23,6"  
 REVESTIMIENTO 15 x 60 cm



**ST304**  
 15x60 M003



**CANTONERA ST304**  
 15x39\* / 15x26\* M004

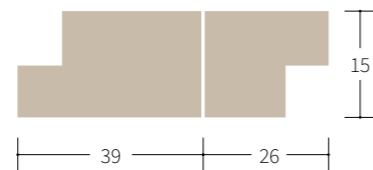

	Prize Code	P./Box	SQM/Box	SQM Palet	Box/Palet	Kg/Piece	Kg/Box	Kg/Palet
ST304 15x60	M003	5	0,45	12,60	28	4,46	22,30	624,40
CANTONERA ST304 15x39 / 15x26	M004							

\* Each corner piece is served in 2 separate pieces *Cada cantonera se sirve en 2 piezas separadas*

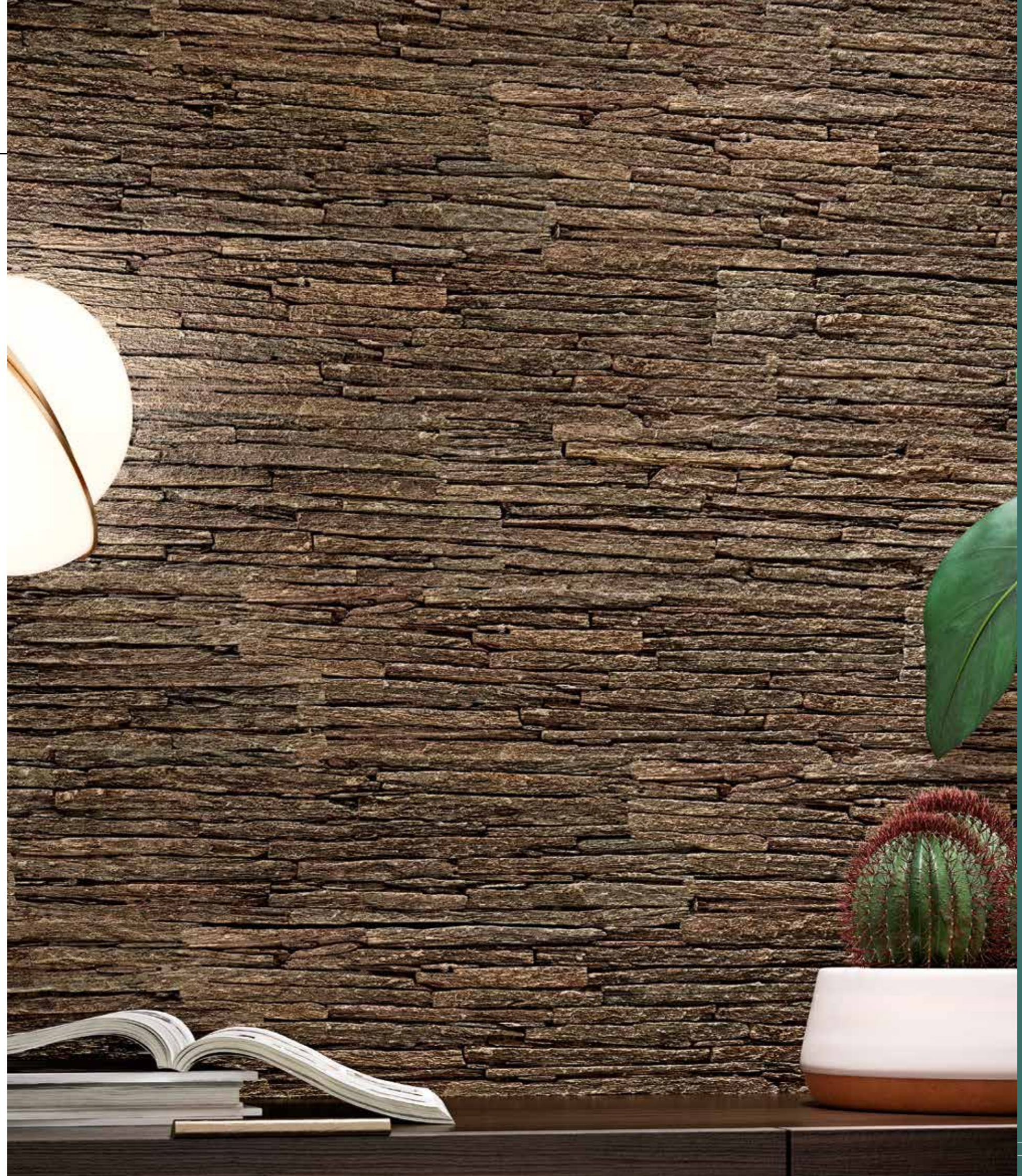

# ST305

WALL 5,9" x 23,6"  
 REVESTIMIENTO 15 x 60 cm



**ST305**  
 15x60 M007



**CANTONERA ST305**  
 15x39\* / 15x26\* M008

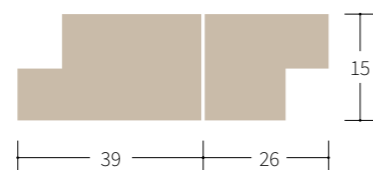

	Prize Code	P./Box	SQM/Box	SQM Palet	Box/Palet	Kg/Piece	Kg/Box	Kg/Palet
ST305 15x60	M007							
CANTONERA ST305 15x39 / 15x26	M008	6	0,54	15,12	28	4,46	26,76	750

\* Each corner piece is served in 2 separate pieces *Cada cantonera se sirve en 2 piezas separadas*





# ST306

WALL 5,9" x 23,6"  
 REVESTIMIENTO 15 x 60 cm



**ST306**  
 15x60 M007



**CANTONERA ST306**  
 15x39\* / 15x26\* M008

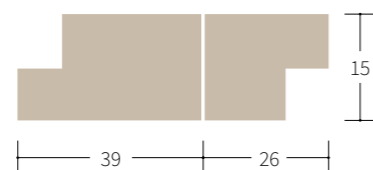

	Prize Code	P./Box	SQM/Box	SQM Palet	Box/Palet	Kg/Piece	Kg/Box	Kg/Palet
ST306 15x60	M007							
CANTONERA ST306 15x39 / 15x26	M008	6	0,54	15,12	28	4,46	26,76	750

\* Each corner piece is served in 2 separate pieces *Cada cantonera se sirve en 2 piezas separadas*

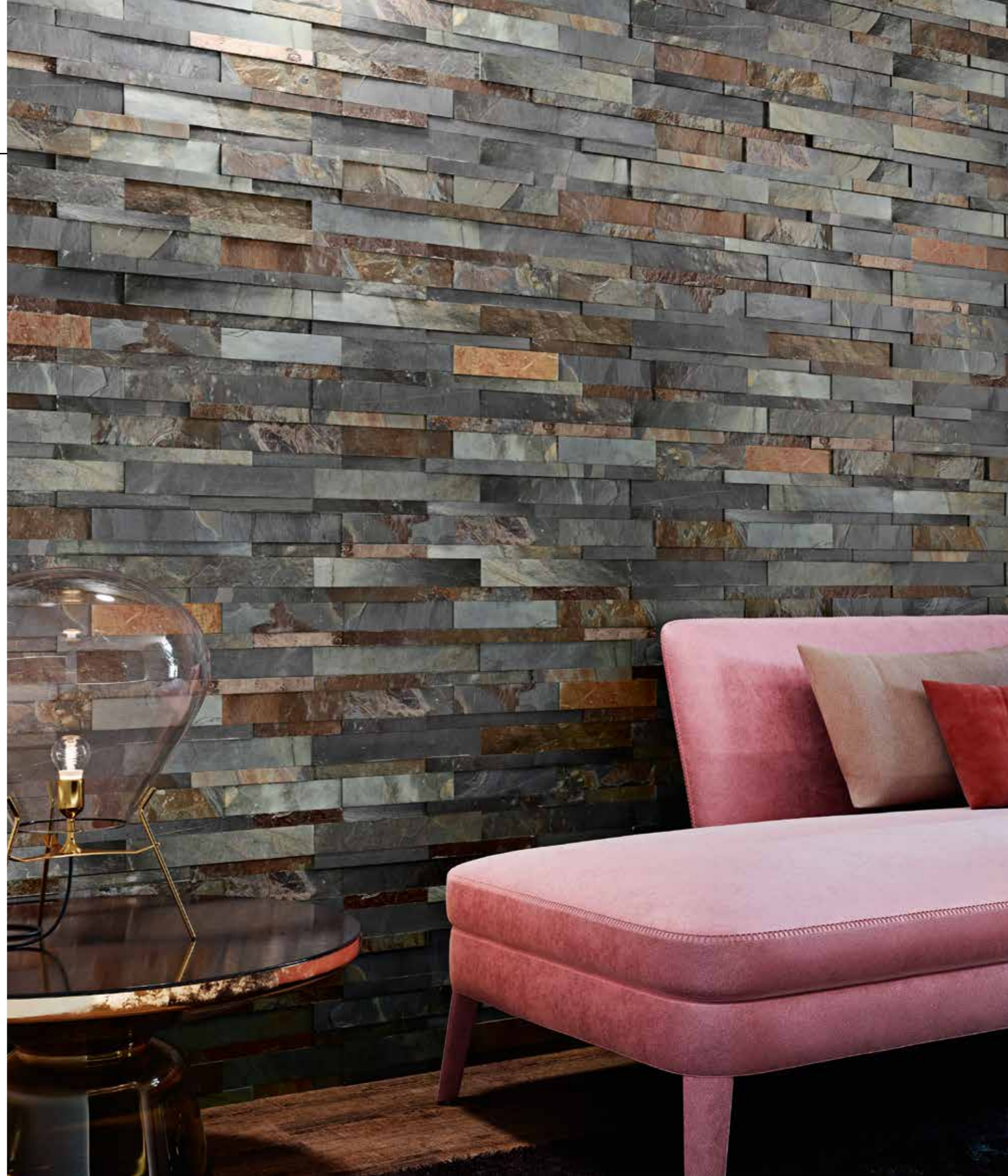

# ST310

WALL 5,9" x 23,6"  
 REVESTIMIENTO 15 x 60 cm



**ST310**  
 15x60 M041



**CANTONERA ST310**  
 15x39\* / 15x26\* M020

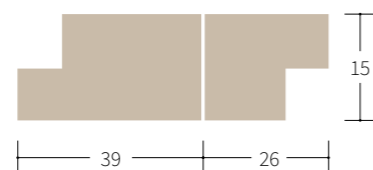

	Prize Code	P./Box	SQM/Box	SQM Palet	Box/Palet	Kg/Piece	Kg/Box	Kg/Palet
ST310 15x60	M041	6	0,54	15,12	28	4,46	26,76	750
CANTONERA ST310 15x39 / 15x26	M020							

\* Each corner piece is served in 2 separate pieces *Cada cantonera se sirve en 2 piezas separadas*

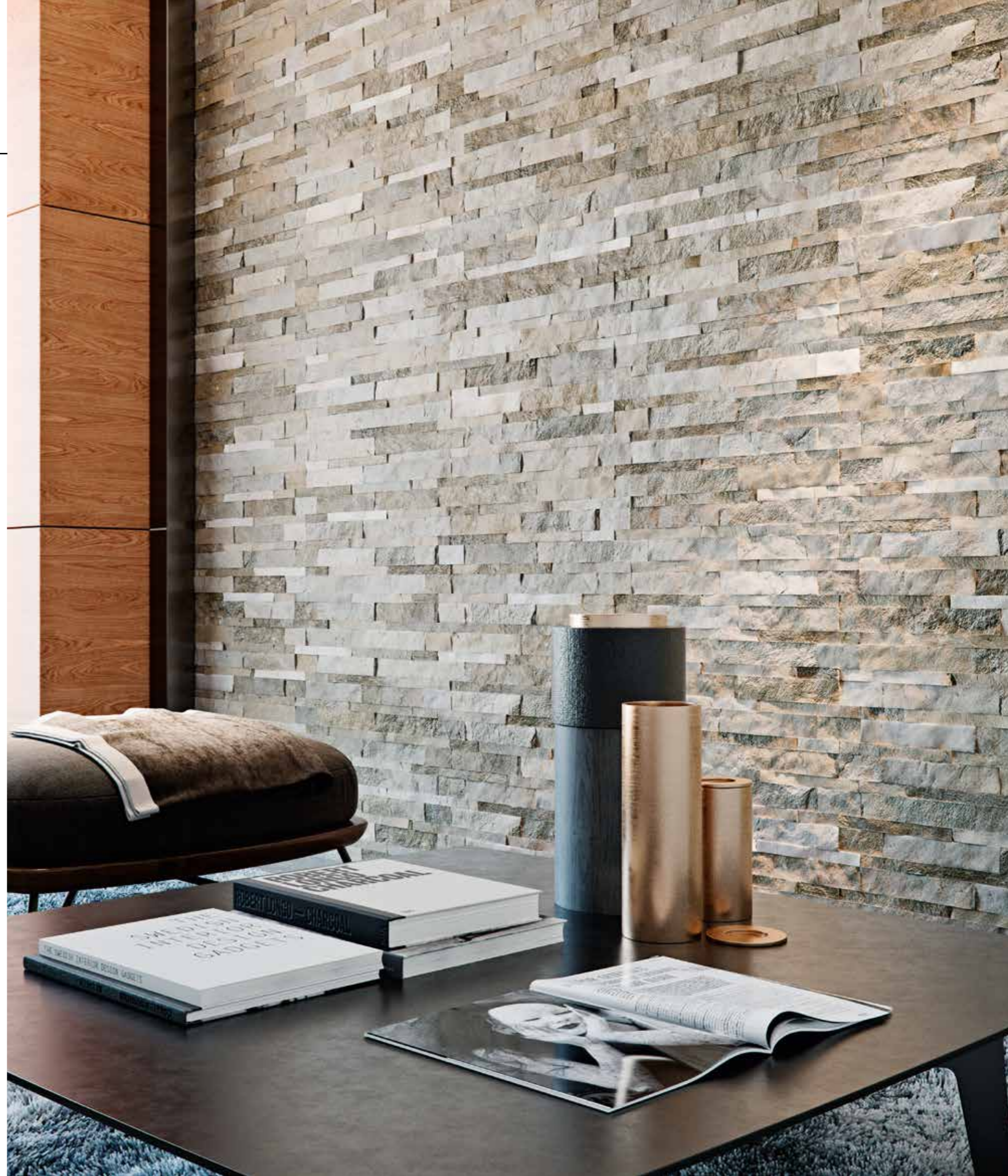



**ST50**  
15x55 M007



**CANTONERA ST50**  
15x37\* / 15x23\* M008



**GOLD GREEN ST301**  
15x60 M019



**CANTONERA ST301**  
15x37\* / 15x23\* M020



**ST51**  
15x55 M007



**CANTONERA ST51**  
15x37\* / 15x23\* M008



**COOPER ST302**  
15x60 M019



**COOPER ST302**  
15x37\* / 15x23\* M020



**ST52**  
15x55 M007



**CANTONERA ST52**  
15x37\* / 15x23\* M008



**COOPER PULIDO**  
30x60 M019



	Prize Code	P./Box	SQM/Box	SQM Palet	Box/Palet	Kg/Piece	Kg/Box	Kg/Palet
ST50 15x55	M007							
CANTONERA ST50 15x37 / 15x23	M008	7	0,578	27,74	48	2,80	19,570	939,36
ST51 15x55	M007							
CANTONERA ST51 15x37 / 15x23	M008	7	0,578	27,74	48	2,80	19,570	939,36
ST52 15x55	M007							
CANTONERA ST52 15x37 / 15x23	M008	7	0,578	27,74	48	2,80	19,570	939,36

	Prize Code	P./Box	SQM/Box	SQM Palet	Box/Palet	Kg/Piece	Kg/Box	Kg/Palet
Gold Green ST301 15x60	M019							
CANTONERA ST301 15x37 / 15x23	M020	8	0,63	26,46	42	3,30	20,40	970,20
Cooper ST302 15x60	M019							
CANTONERA ST302 15x37 / 15x23	M020	8	0,63	26,46	42	3,30	20,40	970,20
Cooper Pulido 30x60	M019	5	0,90	32,40	26	4,46	28,18	1.014,75

# THE MOSAIC

ALHAMA	182	CORTEN	198	LE FONTAINE	212	PARTHENON	242
ALUMINUM	184	D'ARGENT	240	LE PALACE	241	PERLA DOR	226
ANFITEATRO	240	ENIGMA	200	MARFIL SATIN	241	RIN	228
ATENAS	186	ELECTRUM	241	METEORAS	214	STONEHENGE	242
AUREO	240	FLEX 25/50	202	MONTBLANC 01	216	STRATA	230
BOIS	188	GALES	204	MONTBLANC 21	218	SUPERNOVA	242
BUTTON METAL	190	GUERNICA	206	MONTBLANC 25	220	TOTEM	232
CALIFORNIA	240	HIERAPOLIS	241	NEMRUT	241	TRAJANO BEIGE	234
CAPPADOCIA	240	HONEY SPA	241	OBELISCO	222	VALENCIA	236
CEARA	192	ICE SPA	241	ONICE MIEL	242	VERSALLES	238
CEMENT	240	KIEV	208	ONICE BIANCO	242	WHITE PQ	242
COLONIAL	240	LE CITÉ	241	OURO PRETO	224		
CORAL	194	LE CHATEAU	210	PALADIANA BLANCA	242		

The most exquisite mosaics. Discover an infinite range of design possibilities to choose the style that best meets your needs: mosaics, precious stones, stones, glass, metals and eco.

*Los mosaicos más exquisitos. Descubre una infinidad de posibilidades para que puedas elegir el estilo que mejor se adapta a tus necesidades: mosaicos, piedras preciosas, piedras, cristales, metales y eco.*

CERAMICTOUCH  
SHOW IT YOURS



# ALHAMA

WALL / FLOOR 11,8" x 11,8"  
 REVESTIMIENTO / PAVIMENTO 30 x 30 cm



ALHAMA BEIGE 30x30 P070 

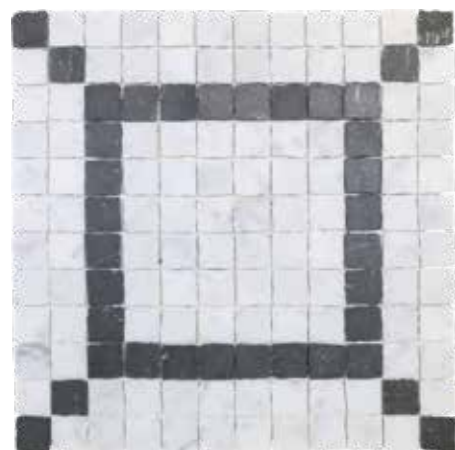

ALHAMA BLANCO 30x30 P071 

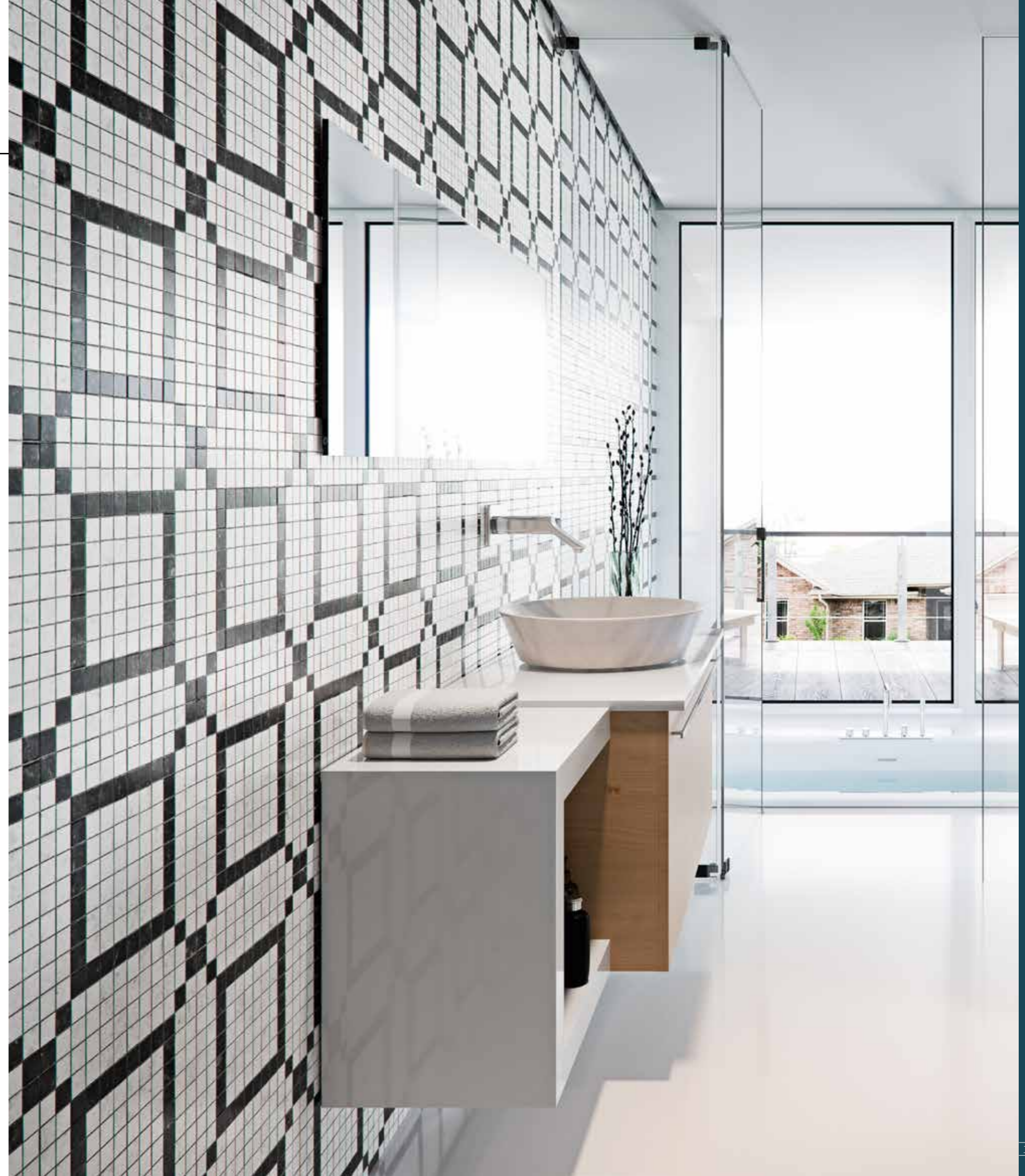

	Prize Code	P./Box	SQM/Box	SQM Palet	Box/Palet	Kg/Piece	Kg/Box	Kg/Palet
Alhama Beige 30x30	P070	6	0,54	25,92	48	1,90	11,76	564,48
Alhama Blanco 30x30	P071							

# ALUMINUM

WALL 11,8" x 11,8"  
 REVESTIMIENTO 30,1 x 30,1 cm



ALUMINUM 30,1x30,1 P016

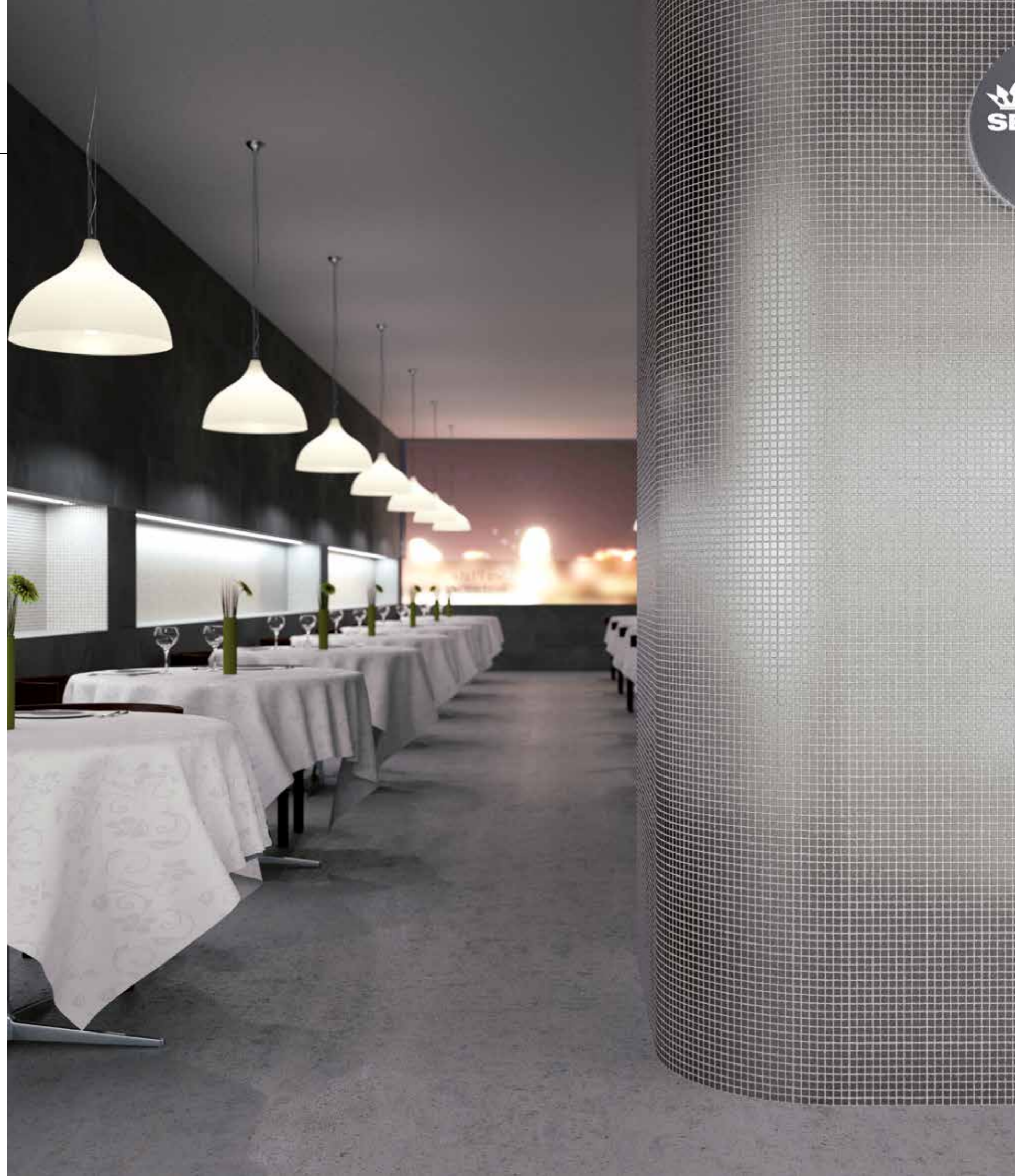

	Prize Code	P./Box	SQM/Box	SQM Palet	Box/Palet	Kg/Piece	Kg/Box	Kg/Palet
ALUMINUM 30,1x30,1	P016	11	1,00	54,00	54	0,90	9,90	534,60

# ATENAS

WALL 11,8" x 11,8" / 11,8" x 11,4" / 11,2" x 11,2" / 12" x 11,2"  
 REVESTIMIENTO 30 x 30 / 29 x 30 / 28,5 x 28,5 / 30,5 x 28,5 cm



ATENAS ART 30x30 P069 



ATENAS BOULDER GRIS 28,5x28,5 P069 

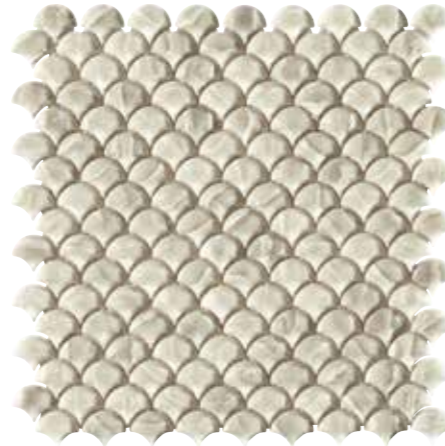

ATENAS FAN 30x30 P069 

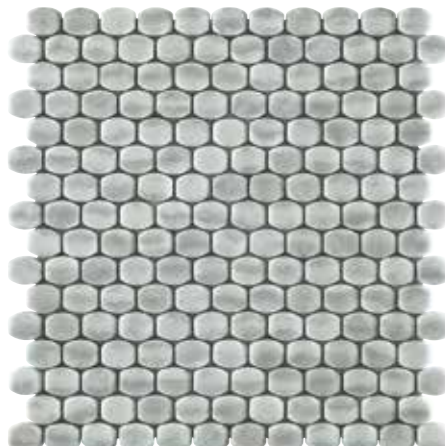

ATENAS OVAL 29x30 P004 



ATENAS DIAMOND 30,5x28,8 P069 

	Prize Code	P./Box	SQM/Box	SQM Palet	Box/Palet	Kg/Piece	Kg/Box	Kg/Palet
Atenas Art 30x30	P069	10	0,90	64,80	72	1,23	12,30	885,60
Atenas Boulder 28,5x28,5	P069	13	1,06	76,03	72	0,92	11,99	863,46
Atenas Fan 30x30	P069	13	1,17	84,24	72	1,23	15,99	1.151,28
Atenas Oval 29x30	P004	13	1,13	81,43	72	1,23	15,99	1.151,28
Atenas Diamond 30,5x28,8	P069	13	1,14	82,22	72	1,23	15,99	1.151,28



# BOIS

WALL 10,4" x 11,8"  
 REVESTIMIENTO 26,4 x 30 cm



BOIS BEIGE 26,4x30 P069



BOIS GRIS 26,4x30 P069



	Prize Code	P./Box	SQM/Box	SQM Palet	Box/Palet	Kg/Piece	Kg/Box	Kg/Palet
Bois Beige 26,4x30	P069	11	0,87	62,73	72	1,89	20,75	1.493,71
Bois Gris 26,4x30								



# BUTTON METAL

WALL 11,8" x 11,8"

REVESTIMIENTO 30 x 30 cm



BUTTON METAL 30x30 P026



	Prize Code	P./Box	SQM/Box	SQM Palet	Box/Palet	Kg/Piece	Kg/Box	Kg/Palet
Button Metal 30x30	P026	12	1,08	69,12	64	1,23	14,76	945

# CEARA

WALL 11,8" x 11,8"

REVESTIMIENTO 30 x 30 cm



CEARA 30x30 P033



Prize Code	P/Box	SQM/Box	SQM Palet	Box/Palet	Kg/Piece	Kg/Box	Kg/Palet
Ceara 30x30	P033	9	58,32	72	1,47	13,23	952,56

# CORAL

WALL 11,8" x 11,8"  
REVESTIMIENTO 30 x 30 cm



# CORAL

WALL 11,8" x 11,8"  
 REVESTIMIENTO 30 x 30 cm



CORAL ART 30x30 P014



CORAL HEXAGON 30x30 P007



CORAL SQUARE 30x30 P051



CORAL STORE 30x30 P051



CORAL OVAL 30x30 P062



	Prize Code	P./Box	SQM/Box	SQM Palet	Box/Palet	Kg/Piece	Kg/Box	Kg/Palet
Coral 30x30	—	33	2,97	187,11	63	0,45	15	945

# CORTEN

WALL 12,4" x 12,4"  
 REVESTIMIENTO 31,5 x 31,5 cm



CORTEN GRIS 31,5X31,5 P022 



CORTEN BEIGE 31,5X31,5 P022 

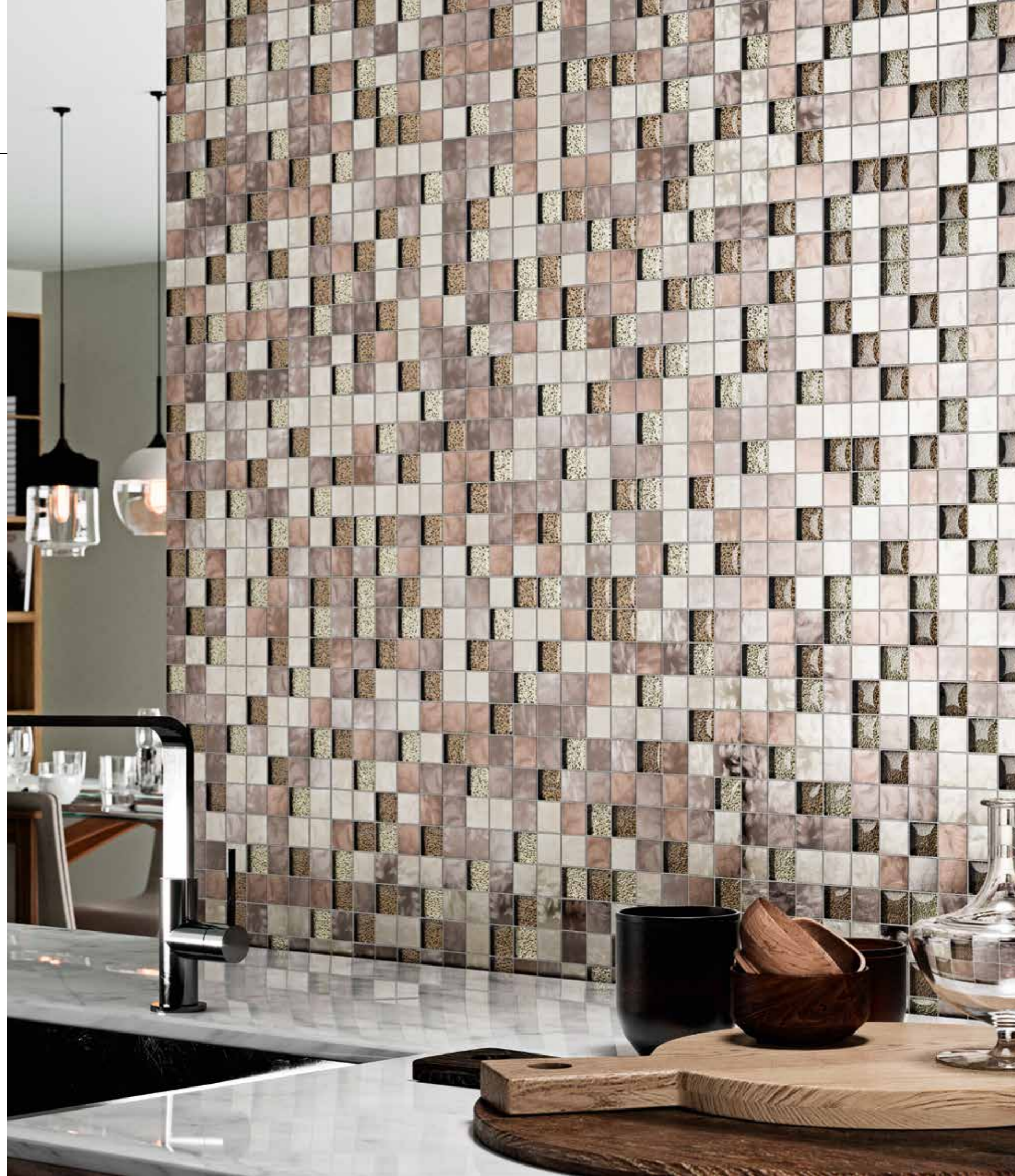

	Prize Code	P/Box	SQM/Box	SQM Palet	Box/Palet	Kg/Piece	Kg/Box	Kg/Palet
Corten Gris 31,5x31,5	P022	9	0,89	58,94	66	1,89	17,01	1.122,66
Corten Beige 31,5x31,5								

# ENIGMA

WALL 11,8" x 11,8"  
REVESTIMIENTO 30,1 x 30,1 cm



ENIGMA 30,1x30,1 P007

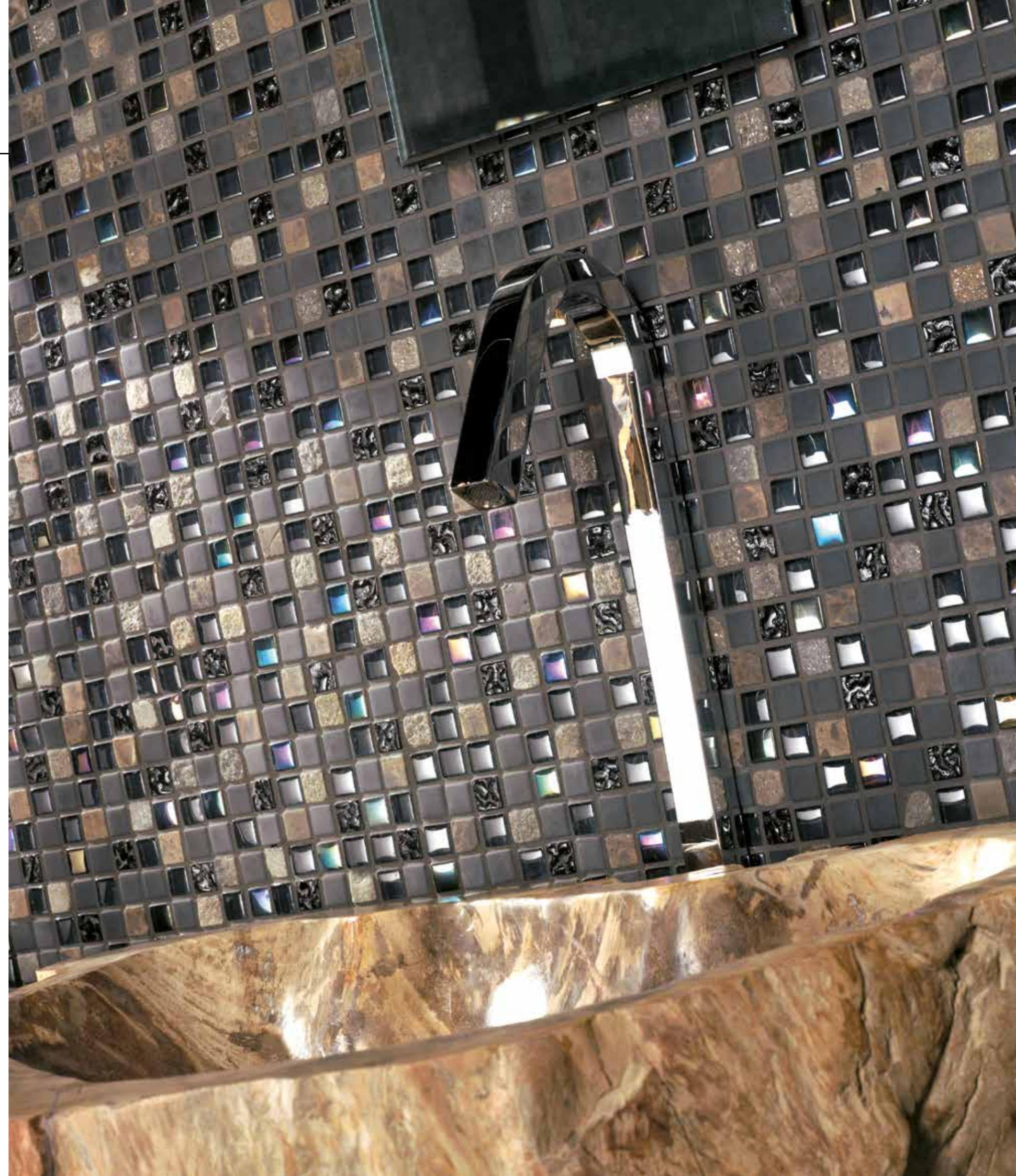

	Prize Code	P./Box	SQM/Box	SQM Palet	Box/Palet	Kg/Piece	Kg/Box	Kg/Palet
Enigma 30,1x30,1	P007	11	1,00	72,00	72	1,35	14,85	1.069,20

# FLEX 25/50

WALL 11,8" x 11,8"  
 REVESTIMIENTO 30 x 30 cm



FLEX 25 30x30 P074



FLEX 50 30x30 P004



	Prize Code	P./Box	SQM/Box	SQM Palet	Box/Palet	Kg/Piece	Kg/Box	Kg/Palet
<b>Flex 25 30x30</b>	<b>P074</b>	40	3,60	162	45	0,15	6,15	276,75
<b>Flex 50 30x30</b>	<b>P004</b>							

# GALES

WALL / FLOOR 10,6" x 10,6"  
 REVESTIMIENTO / PAVIMENTO 27 x 27 cm



GALES BEIGE 27X27 P071

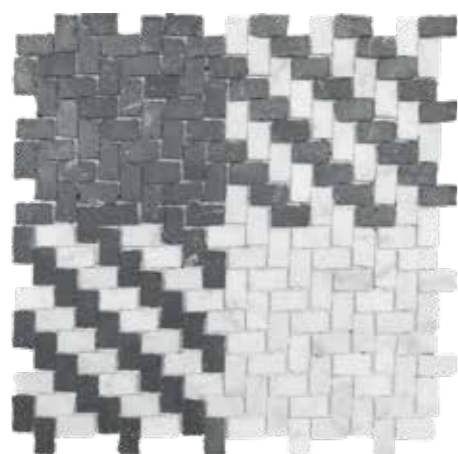

GALES BLANCO 27X27 P073



	Prize Code	P./Box	SQM/Box	SQM Palet	Box/Palet	Kg/Piece	Kg/Box	Kg/Palet
Gales Beige 27x27	P071	6	0,44	21	48	1,96	11,76	564,48
Gales Blanco 27x27	P073							



# GUERNICA

WALL 11,8" x 11,8"

REVESTIMIENTO 30 x 30 cm



GUERNICA BLANCO 30x30 P055



	Prize Code	P./Box	SQM/Box	SQM Palet	Box/Palet	Kg/Piece	Kg/Box	Kg/Palet
Guernica Blanco 30x30	P055	9	0,81	58,32	72	1,27	11,71	843,54

# KIEV

WALL 11,8" x 11,8"

REVESTIMIENTO 30 x 30 cm



KIEV 30x30 P010



	Prize Code	P/Box	SQM/Box	SQM Palet	Box/Palet	Kg/Piece	Kg/Box	Kg/Palet
Kiev 30x30	P010	5	0,45	32,45	72	3,05	15,25	1.098

# LE CHATEAU

WALL / FLOOR 12" x 12"

REVESTIMIENTO / PAVIMENTO 30,5 x 30,5 cm



LE CHATEAU 30,5x30,5 P001

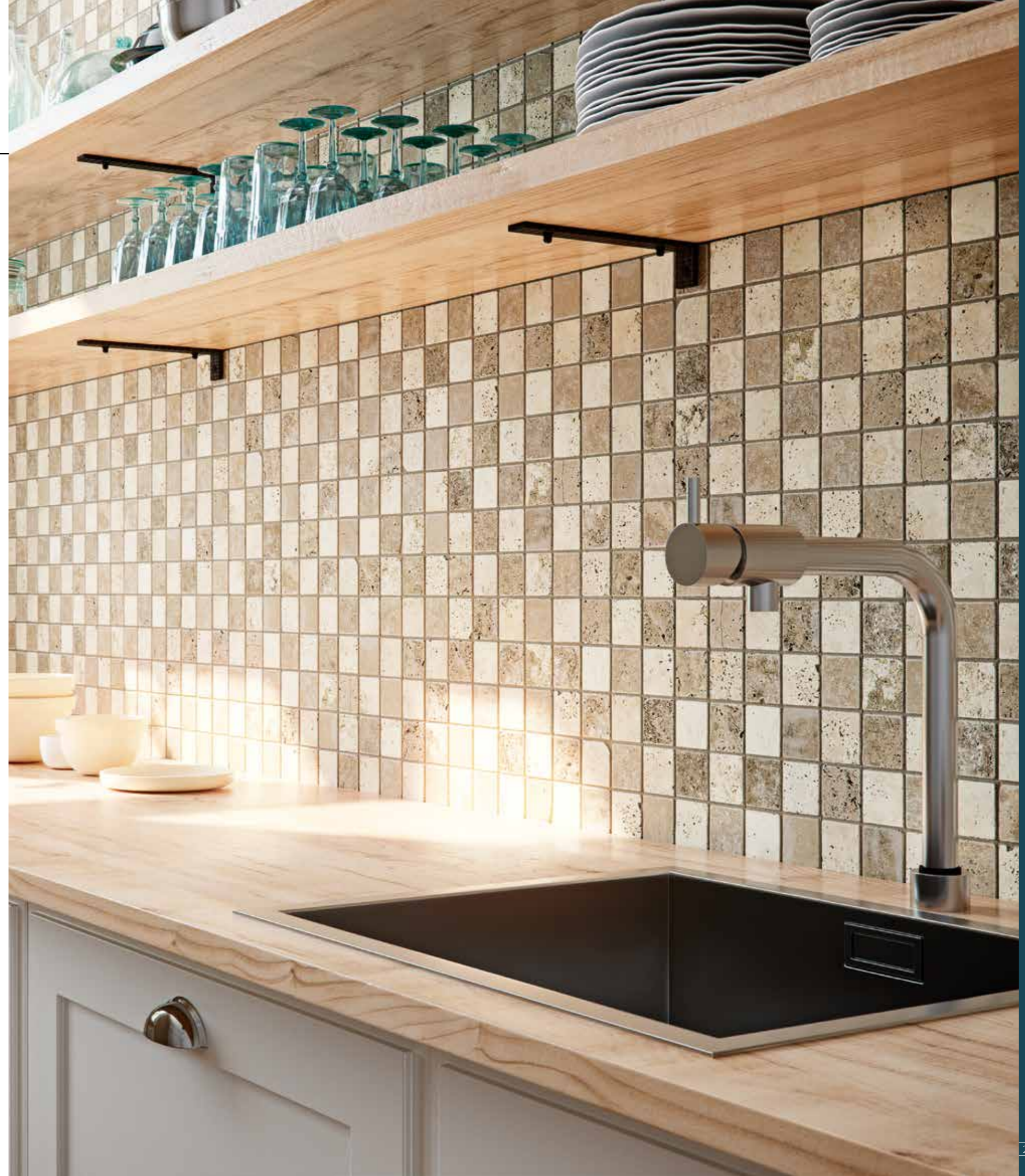

	Prize Code	P/Box	SQM/Box	SQM Palet	Box/Palet	Kg/Piece	Kg/Box	Kg/Palet
Le Chateau 30,5x30,5	P001	10	0,93	66,97	72	1,65	16,50	1.188

# LE FONTAINE

WALL / FLOOR 12" x 12"

REVESTIMIENTO / PAVIMENTO 30,5 x 30,5 cm



LE FONTAINE 30,5x30,5 P039



	Prize Code	P./Box	SQM/Box	SQM Palet	Box/Palet	Kg/Piece	Kg/Box	Kg/Palet
Le Fontaine 30,5x30,5	P039	10	0,93	50,23	54	2,20	22	1.190

# METEORAS

WALL / FLOOR 10,2" x 10,2"

REVESTIMIENTO / PAVIMENTO 26 x 26 cm



METEORAS 26x26 P008

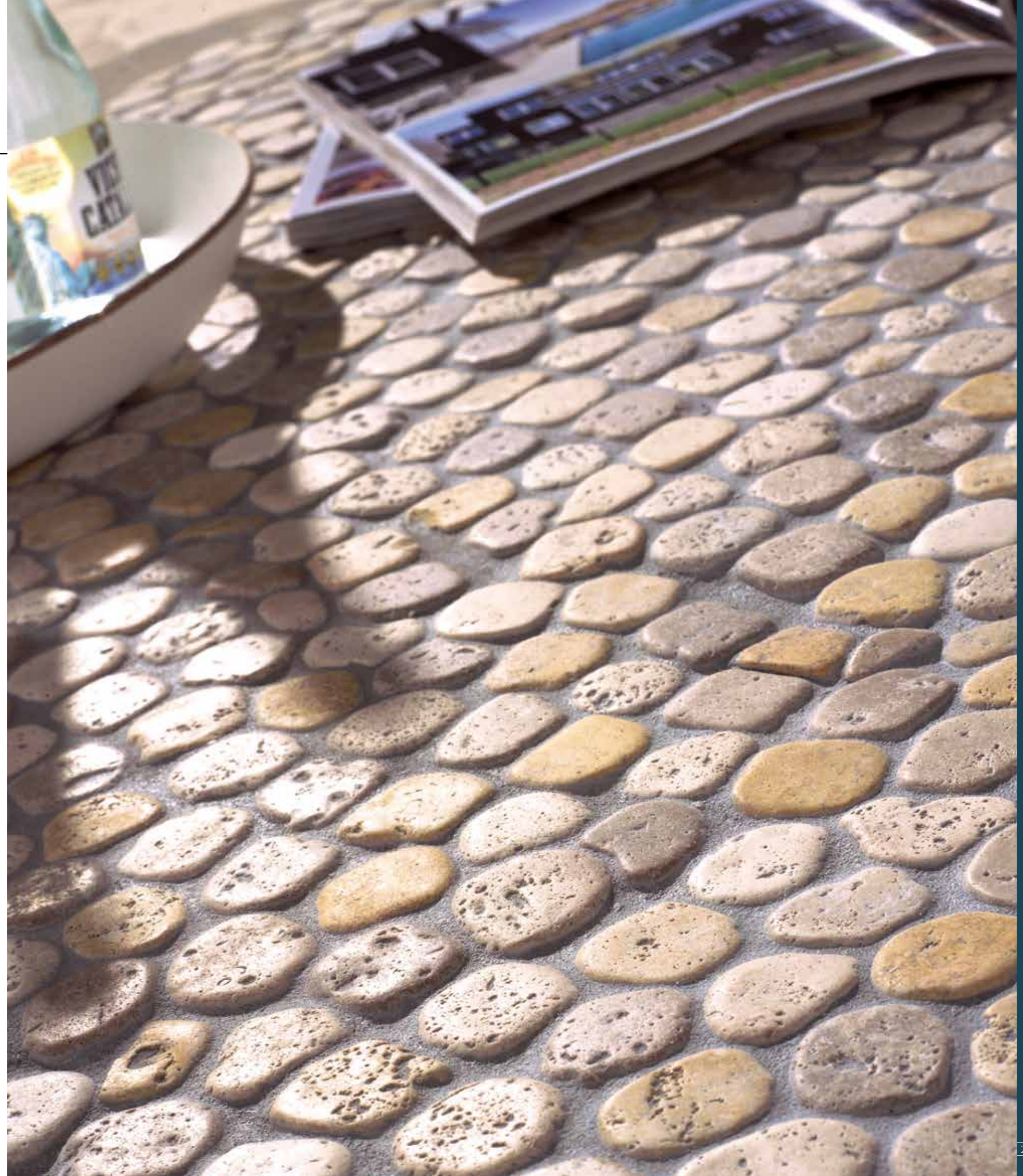

	Prize Code	P./Box	SQM/Box	SQM Palet	Box/Palet	Kg/Piece	Kg/Box	Kg/Palet
Meteoras 26x26	P008	8	0,54	38,94	72	1,25	10,00	720

# MONTBLANC 01

WALL 13,4" x 11"

REVESTIMIENTO 32,4 x 28 cm



MONTBLANC 01 32,4x28 P062



	Prize Code	P/Box	SQM/Box	SQM Palet	Box/Palet	Kg/Piece	Kg/Box	Kg/Palet
Montblanc 01 32,4x28	P062	14	1,27	91,45	72	1,18	16,50	1.188,18

# MONTBLANC 21

WALL 13,4" x 11"

REVESTIMIENTO 32,4 x 28 cm



MONTBLANC 21 32,4x28 P062



	Prize Code	P/Box	SQM/Box	SQM Palet	Box/Palet	Kg/Piece	Kg/Box	Kg/Palet
Montblanc 21 32,4x28	P062	14	1,27	91,45	72	1,18	16,50	1.188,18

# MONTBLANC 25

WALL 13,4" x 11"  
REVESTIMIENTO 32,4 x 28 cm



MONTBLANC 25 32,4x28 P062

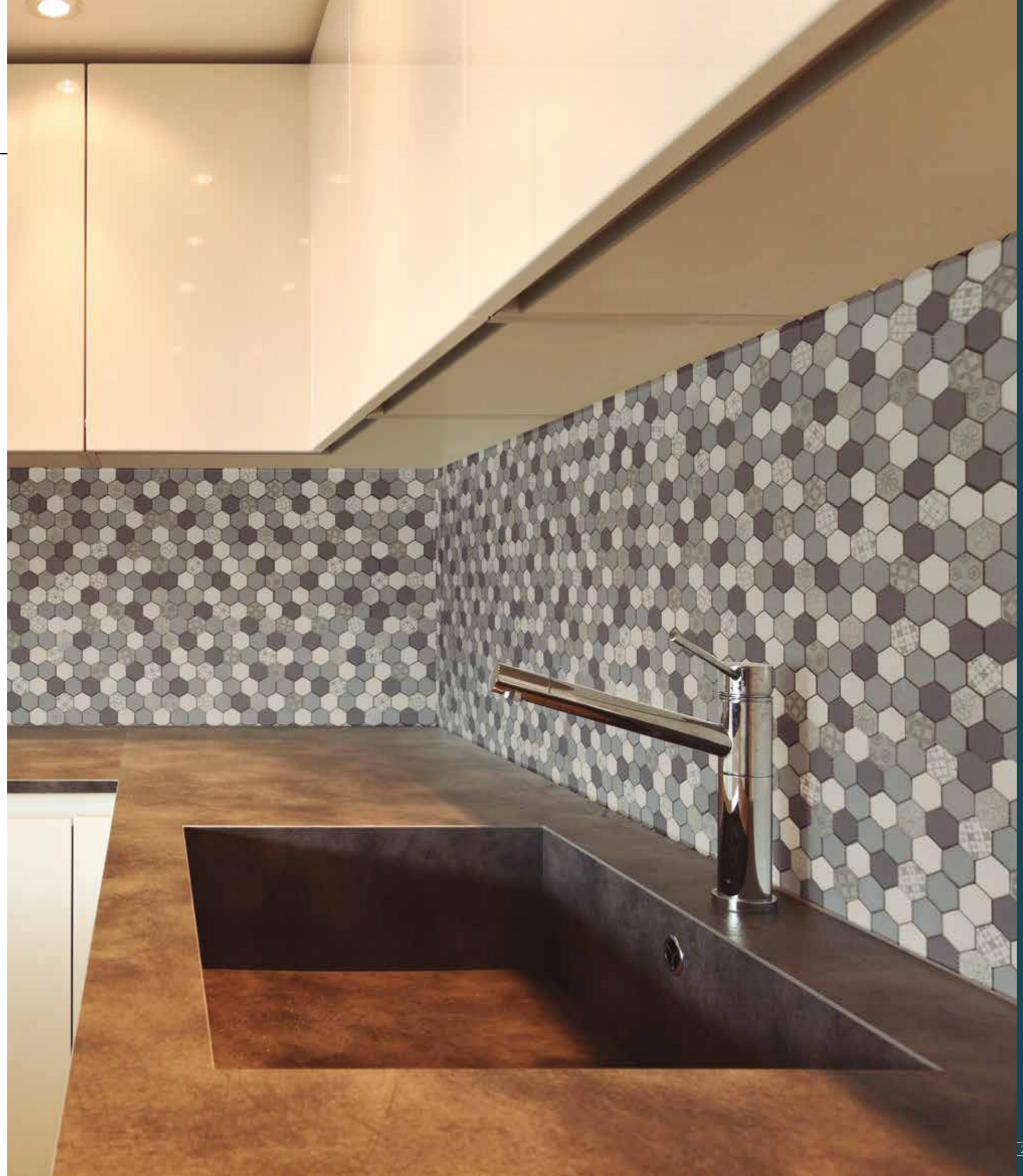

	Prize Code	P./Box	SQM/Box	SQM Palet	Box/Palet	Kg/Piece	Kg/Box	Kg/Palet
Montblanc 25 32,4x28	P062	14	1,27	91,45	72	1,18	16,50	1.188,18



# OBELISCO

WALL 11,8" x 11,8"

REVESTIMIENTO 30 x 30 cm

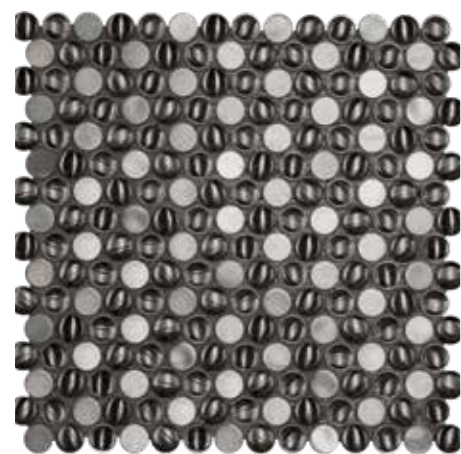

OBELISCO METAL 30x30 P058



	Prize Code	P./Box	SQM/Box	SQM Palet	Box/Palet	Kg/Piece	Kg/Box	Kg/Palet
Obelisco Metal 30x30	P058	11	1,00	45,00	45	0,87	9,57	430,65

# OURO PRETO

WALL / FLOOR 9,8" x 11,8"

REVESTIMIENTO / PAVIMENTO 25 x 30 cm

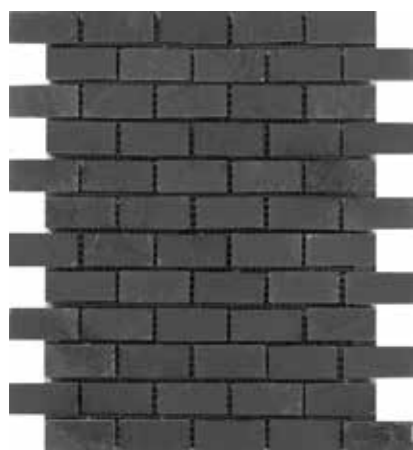

OURO PETRO 25x30 P001

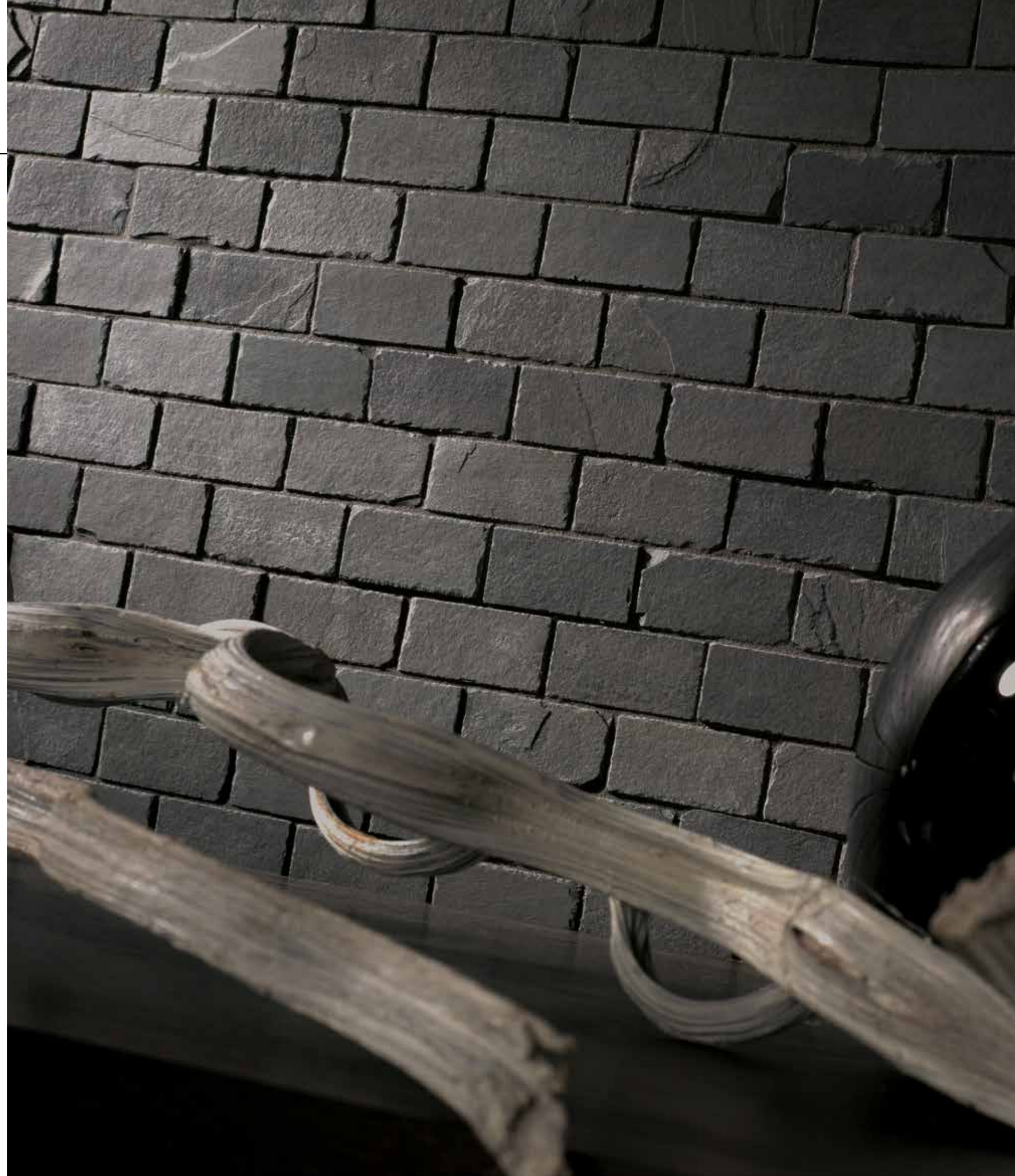

	Prize Code	P/Box	SQM/Box	SQM Palet	Box/Palet	Kg/Piece	Kg/Box	Kg/Palet
Ouro Preto 25x30	P001	10	0,75	40,50	54	1,46	14,56	786,24

# PERLA DOR

WALL 11,8" x 11,8"

REVESTIMIENTO 30,1 x 30,1 cm

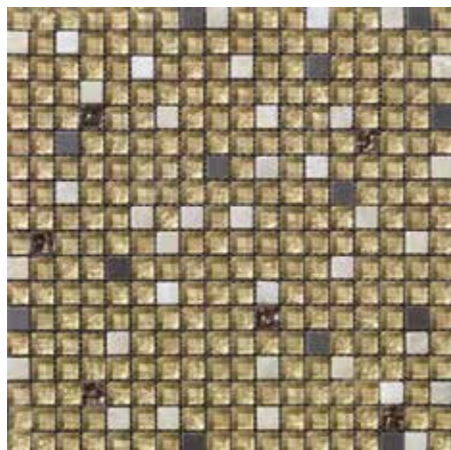

PERLA DOR 30,1x30,1 P011



	Prize Code	P./Box	SQM/Box	SQM Palet	Box/Palet	Kg/Piece	Kg/Box	Kg/Palet
--	------------	--------	---------	-----------	-----------	----------	--------	----------

Perla Dor 30,1x30,1	P011	11	1,00	54,00	54	1,30	14,30	772,20
---------------------	------	----	------	-------	----	------	-------	--------

# RIN

WALL / FLOOR 11,8" x 11,8" / 23,6" x 65"  
 REVESTIMIENTO / PAVIMENTO 30 x 30 cm / 60 x 165 cm



**RIN BLANCA** 30x30 P027  
60x165 P066



**RIN GRIS** 30x30 P027  
60x165 P066



**RIN BEIGE** 30x30 P027  
60x165 P066



**RIN MARRÓN** 30x30 P027  
60x165 P066



**RIN NEGRO** 30x30 P027  
60x165 P066



**RIN 60x165 P066**  
Available in all colors  
*Disponible en todos los colores*



	Prize Code	P./Box	SQM/Box	SQM Palet	Box/Palet	Kg/Piece	Kg/Box	Kg/Palet
<b>Rin 30x30</b>	<b>P027</b>	<b>22</b>	<b>1,98</b>	<b>106,92</b>	<b>54</b>	<b>0,87</b>	<b>19,14</b>	<b>1.033,56</b>
<b>Rin 60x165</b>	<b>P066</b>	<b>1</b>	<b>0,99</b>	<b>71,29</b>	<b>72</b>	<b>9,33</b>	<b>9,33</b>	<b>671,76</b>

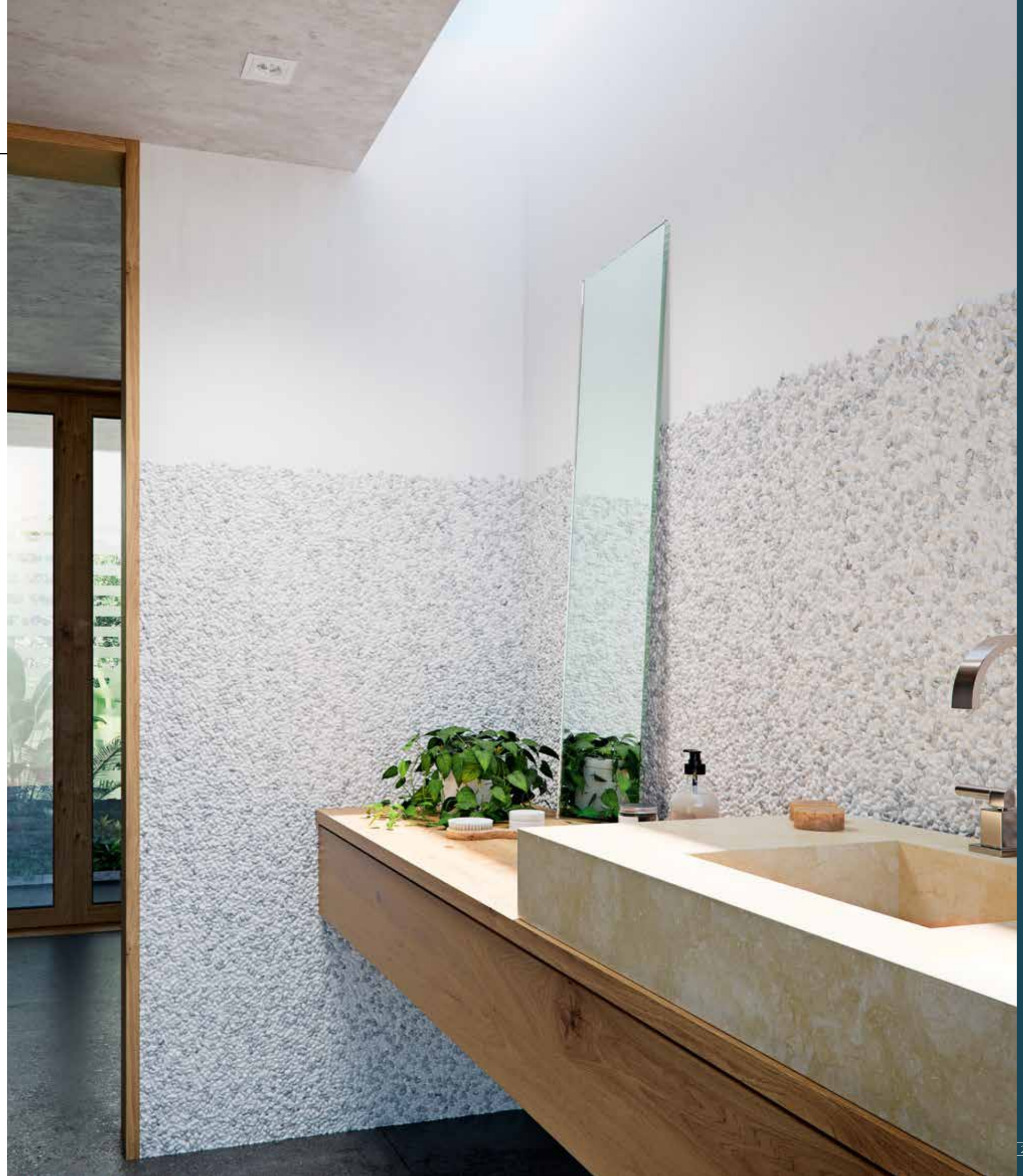

# STRATA

WALL / FLOOR 11,4" x 11,4"  
 REVESTIMIENTO / PAVIMENTO 29 x 29 cm



STRATA BEIGE 29x29 P071 

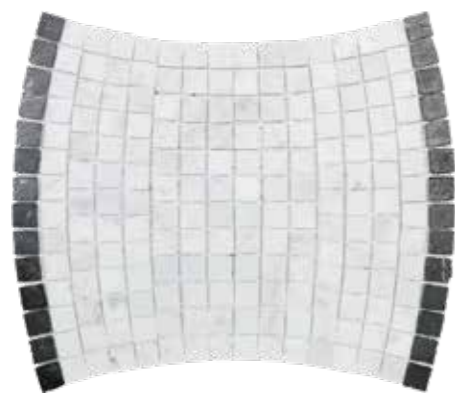

STRATA BLANCO 29x29 P072 



	Prize Code	P./Box	SQM/Box	SQM Palet	Box/Palet	Kg/Piece	Kg/Box	Kg/Palet
Strata Beige 29x29	P071	6	0,54	24,22	48	1,96	11,76	564,48
Strata Blanco 29x29	P072							

# TOTEM

WALL 11,8" x 11,8"

REVESTIMIENTO 30 x 30 cm



TOTEM 30x30 P039



	Prize Code	P./Box	SQM/Box	SQM Palet	Box/Palet	Kg/Piece	Kg/Box	Kg/Palet
Totem 30x30	P039	10	0,90	40,50	45	2,10	21,00	945,56

# TRAJANO BEIGE

WALL 11,8" x 11,8"

REVESTIMIENTO 30 x 30 cm



TRAJANO BEIGE 30x30 P059

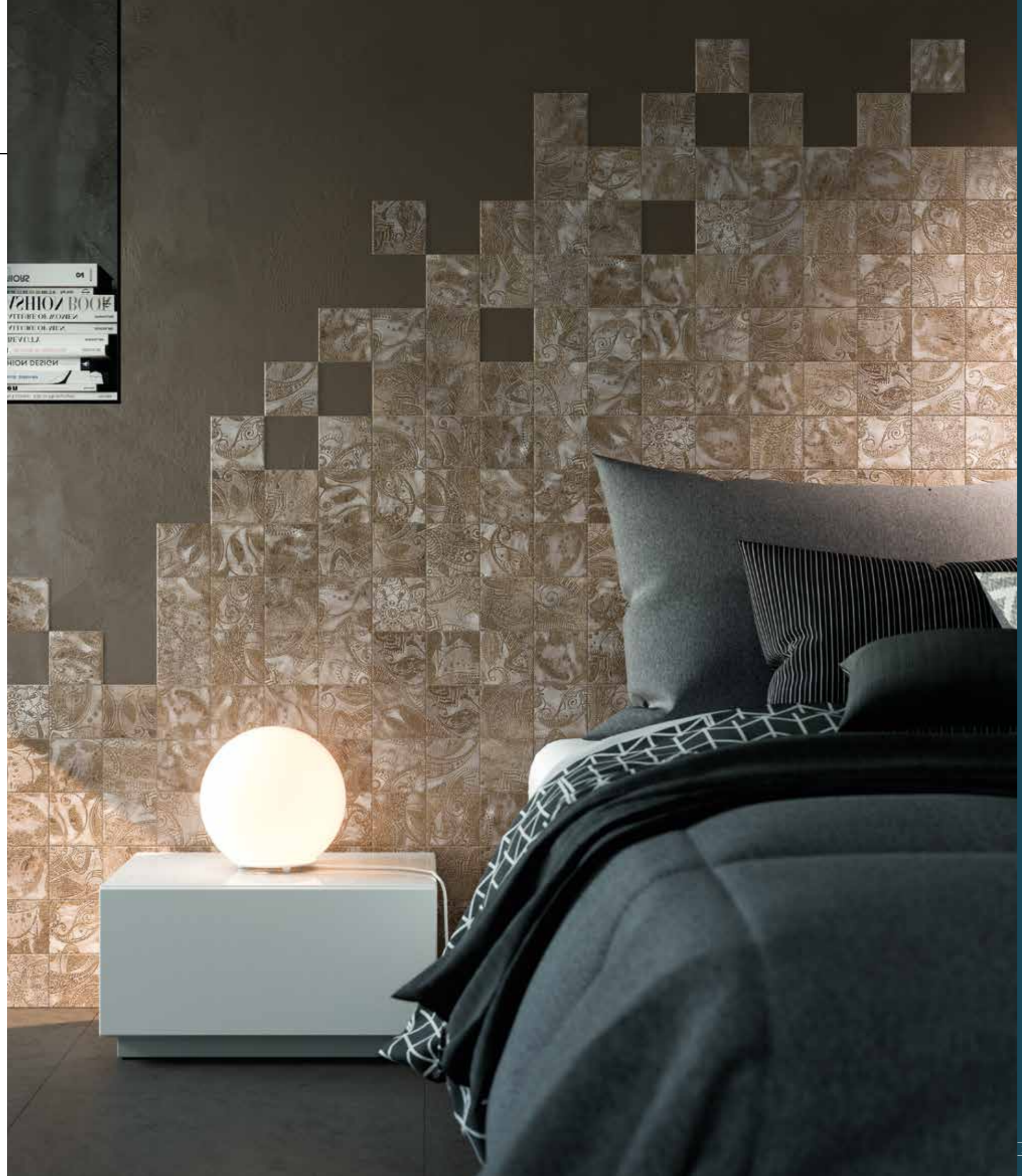

	Prize Code	P./Box	SQM/Box	SQM Palet	Box/Palet	Kg/Piece	Kg/Box	Kg/Palet
Trajano Beige 30x30	P059	9	0,81	58,32	72	1,38	12,45	896,67

# VALENCIA

WALL 11,8" x 11,8"

REVESTIMIENTO 30,1 x 30,1 cm



VALENCIA 30,1x30,1 P007



	Prize Code	P./Box	SQM/Box	SQM Palet	Box/Palet	Kg/Piece	Kg/Box	Kg/Palet
Valencia 30,1x30,1	P007	11	1,00	54,00	54	1,35	14,85	801,90



# VERSALLES

FLOOR / WALL 12" x 12"

PAVIMENTO / REVESTIMIENTO 30,5 x 30,5 cm



VERSALLES 30,5x30,5 P039



	Prize Code	P/Box	SQM/Box	SQM Palet	Box/Palet	Kg/Piece	Kg/Box	Kg/Palet
Versalles 30,1x30,1	P039	10	0,93	66,97	72	2,15	22	1.584



ANFITEATRO 26x26 P006

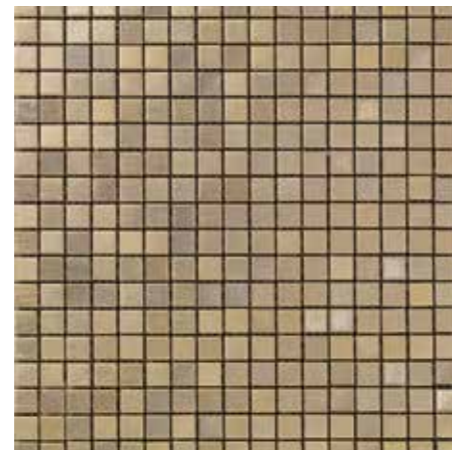

AUREO 30,1x30,1 P019



BIANCONE 30x30 P037



ELECTRUM 30,5x30,5 P006



HIERÁPOLIS 30,5x30,5 P013



HONEY SPA 30,1x30,1 P001



CALIFORNIA 30x30 P003



CAPPADOCIA 26x26 P008

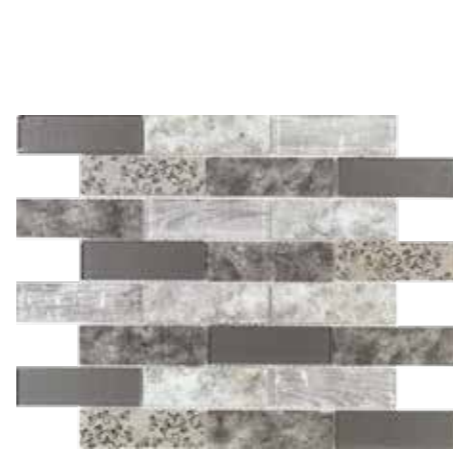

CEMENT 26,4x30 P069

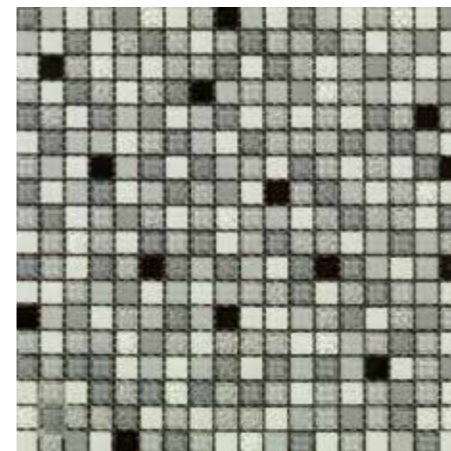

ICE SPA 30,1x30,1 P001

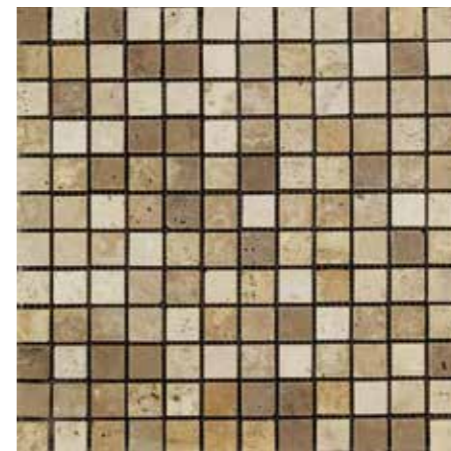

LE CITÉ 30,5x30,5 P003

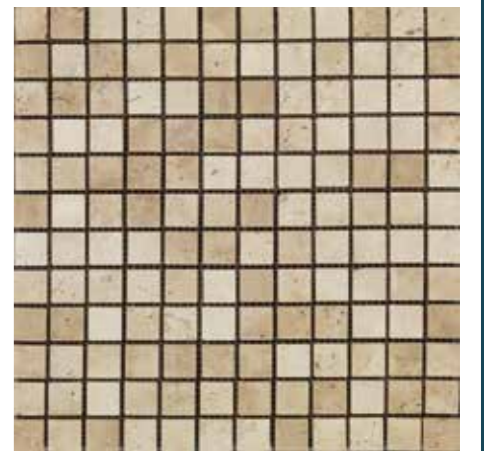

LE PALACE 30,5x30,5 P003

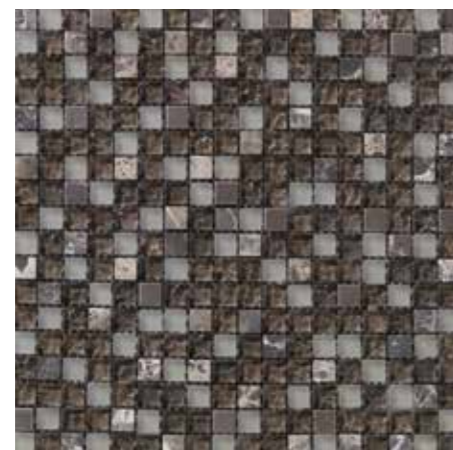

COLONIAL 30,1x30,1 P011

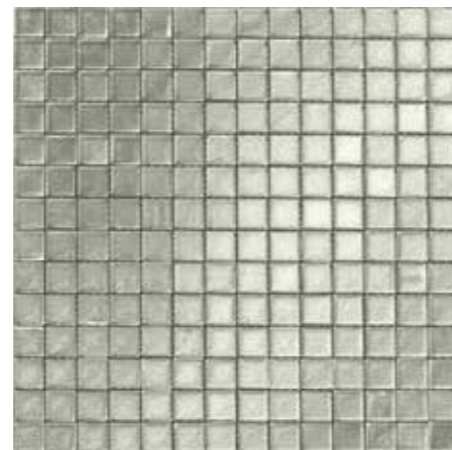

D'ARGENT 30x30 P012



MARFIL SATIN 30,5x30,5 P006

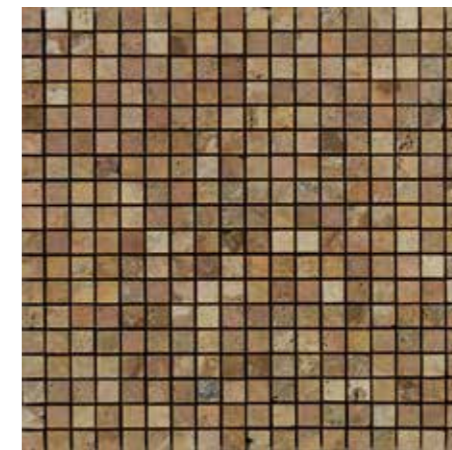

NEMRUT 30,5x30,5 P006



	Prize Code	P./Box	SQM/Box	SQM Palet	Box/Palet	Kg/Piece	Kg/Box	Kg/Palet
Anfiteatro 26x26	P006	10	0,68	48,67	72	1,15	11,50	828
Aureo 30,1x30,1	P019	11	1	54,00	54	1,15	12,65	683,10
Biancone 30x30	P037	10	0,90	64,80	72	1,45	14,50	1.044
California 30x30	P003	10	0,90	40,50	45	1,66	16,61	747,45
Cappadocia 26x26	P008	8	0,54	38,94	72	1,40	11,20	806,40
Cement 26,4x30	P069	11	0,87	62,73	72	1,89	20,75	1.494
Colonial 30,1x30,1	P011	11	1	54,00	54	1,35	14,85	801,90
D'Argent 30x30	P012	11	0,99	53,46	54	1,55	17,05	920,70

	Prize Code	P./Box	SQM/Box	SQM Palet	Box/Palet	Kg/Piece	Kg/Box	Kg/Palet
Electrum 30,5x30,5	P006	10	0,93	66,97	72	1,45	14,50	1.044
Hierapolis 30,5x30,5	P013	10	0,93	66,97	72	1,50	15,00	1.080
Honey Spa 30,1x30,1	P001	20	1,81	97,74	54	0,70	14,00	756
Ice Spa 30,1x30,1	P001	20	1,81	97,74	54	0,70	15,00	810
Le Cité 30,5x30,5	P003	10	0,93	66,97	72	1,45	14,50	1.044
Le Palace 30,5x30,5	P003	10	0,93	66,97	72	1,50	15,00	1.080
Marfil Satin 30,5x30,5	P006	10	0,93	66,97	72	1,55	15,50	1.116
Nemrut 30,5x30,5	P006	10	0,93	66,97	72	1,45	14,50	1.044

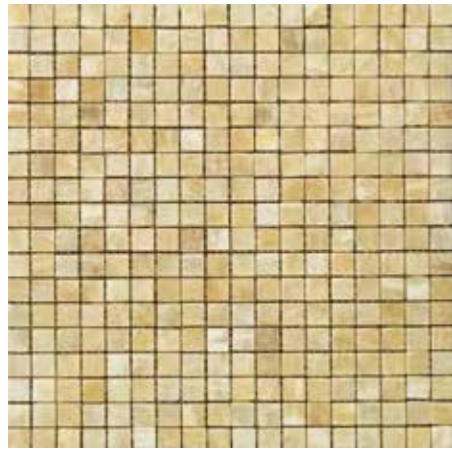

ONICE MIEL 30,5x30,5 P014



ONICE BIANCO 30,5x30,5 P015

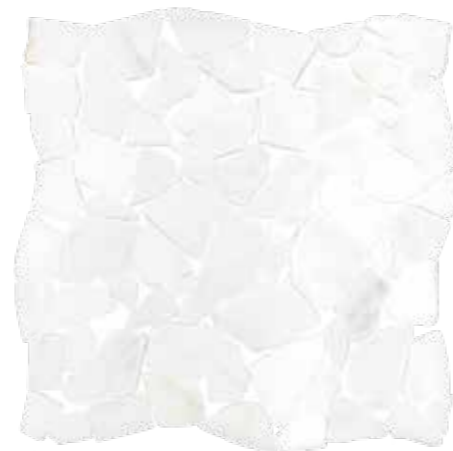

PALADIANA BLANCA 30x30 P069



PARTHENON 30x30 P003



STONEHENGE 30,5x30,5 P006

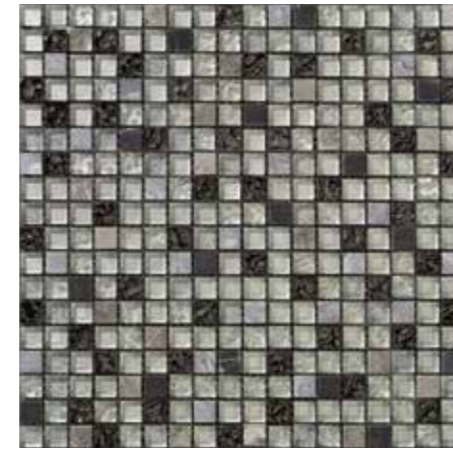

SUPERNOVA 30,1x30,1 P007



WHITE PQ 30x30 P038



	Prize Code	P./Box	SQM/Box	SQM Palet	Box/Palet	Kg/Piece	Kg/Box	Kg/Palet
Onice Miel 30,5x30,5	P014	10	0,93	66,97	72	1,55	15,25	1.116
Onice Bianco 30,5x30,5	P015	10	0,93	66,97	72	1,55	16	1.152
Paladiana Blanca 30x30	P069	10	0,90	64,80	72	1,40	14,00	1.008
Parthenon 30x30	P003	10	0,90	40,50	45	1,66	16,61	747,45
Stonehenge 30,5x30,5	P006	10	0,93	58,60	63	1,95	19,50	1.228,50
Supernova 30,1x30,1	P007	11	1,00	54,00	54	1,40	15,40	831,60
White PQ 30x30	P038	7	0,64	34,36	54	1,95	13,65	737,10

# ONAREA

SINGULAR	246
FINE	256
ARQUITECT	268
RIN	274
BASINS LAVABOS	278
TECHNICAL CHARACTERISTICS CARACTERÍSTICAS TÉCNICAS	312

Nature is the starting point of this collection.  
Our designs are specially known for creating comfortable, secure and high quality atmospheres.  
Our materials join the characteristics and high performances of natural stone with the latest generation materials. This way they are adjustable to each project.  
We have the collection ONAREA that allows to carry out each Project, residential or public. Designs adaptable to the environment.  
Our main purpose is offer solutions to build robust and quality ecosystems.

*La naturaleza es el punto de partida de esta colección.  
Hemos creado unos diseños especialmente pensados para generar hábitats confortables, seguros y de calidad.  
Nuestros materiales aúnan las características y altas prestaciones de la piedra natural con los materiales de última generación. Así se adaptan a cada proyecto.  
Así hemos pensado las colecciones de ONAREA. Una colección que permite realizar cualquier tipo de proyecto, ya sea residencial o público. Diseños que se adaptan a su entorno, ajustándose a las necesidades de cada espacio.  
Nuestro objetivo es ofrecer soluciones con altas prestaciones y diseños elegantes sobre los que levantar ecosistemas robustos y de calidad.*

CERAMICTOUCH  
View it with 



# SINGULAR



SINGULAR MARENGO CA 75x150x3

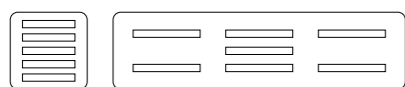

All the grids in Singular collection are available in the same finish as the tray.  
*Todos los platos Singular disponen de la opción de la rejilla en el mismo acabado que el plato.*

All the Singular trays are available with BR, CA, PL y TR finishes.  
Stand measures wide 70 to 100, length 80 to 200. Also made to measure.

*Todos los platos Singular están disponibles con los acabados BR, CA, PL y TR.  
Todos los platos Singular se fabrican en medidas estándar de ancho 70-100cm y largo de 80-200cm. También en medida personalizada.*



# SINGULAR

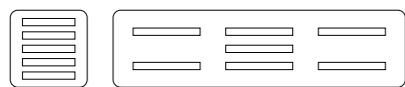

All the grids in Singular collection are available in the same finish as the tray.  
*Todos los platos Singular disponen de la opción de la rejilla en el mismo acabado que el plato.*

All the Singular trays are available with BR, CA, PL y TR finishes.  
Stand measures wide 70 to 100, length 80 to 200. Also made to measure.

*Todos los platos Singular están disponibles con los acabados BR, CA, PL y TR.  
Todos los platos Singular se fabrican en medidas estándar de ancho 70-100cm y largo de 80-200cm. También en medida personalizada.*



# SINGULAR

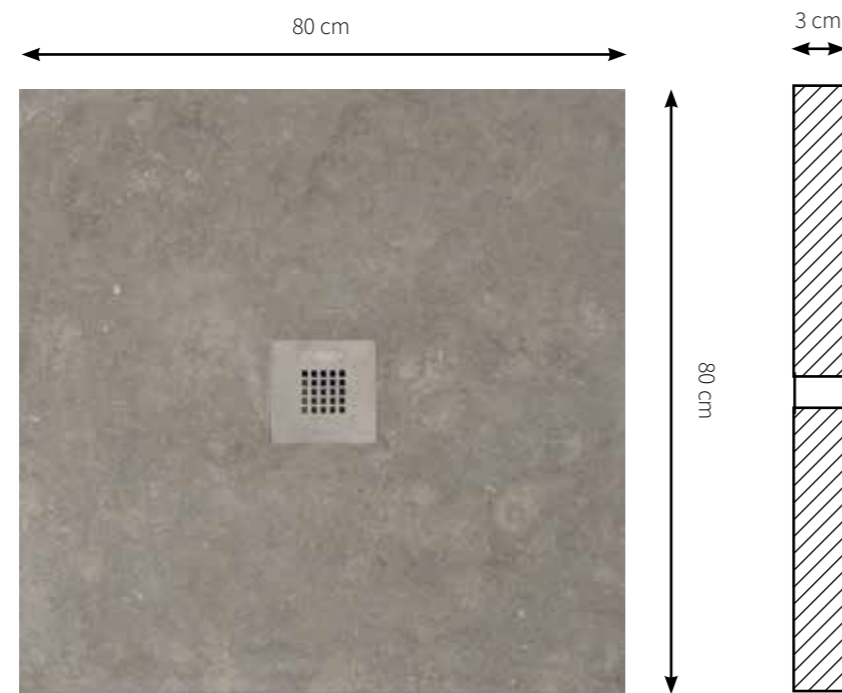

SINGULAR GRIS PL 80x80x3



SINGULAR CREMA PL TR 90x120x3

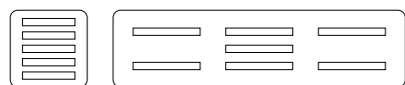

All the grids in Singular collection are available in the same finish as the tray.  
*Todos los platos Singular disponen de la opción de la rejilla en el mismo acabado que el plato.*

All the Singular trays are available with BR, CA, PL y TR finishes.  
 Stand measures wide 70 to 100, length 80 to 200. Also made to measure.

*Todos los platos Singular están disponibles con los acabados BR, CA, PL y TR.  
 Todos los platos Singular se fabrican en medidas estándar de ancho 70-100cm y largo de 80-200cm.  
 También en medida personalizada.*

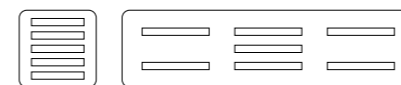

All the grids in Singular collection are available in the same finish as the tray.  
*Todos los platos Singular disponen de la opción de la rejilla en el mismo acabado que el plato.*

All the Singular trays are available with BR, CA, PL y TR finishes.  
 Stand measures wide 70 to 100, length 80 to 200. Also made to measure.

*Todos los platos Singular están disponibles con los acabados BR, CA, PL y TR.  
 Todos los platos Singular se fabrican en medidas estándar de ancho 70-100cm y largo de 80-200cm.  
 También en medida personalizada.*

# SINGULAR

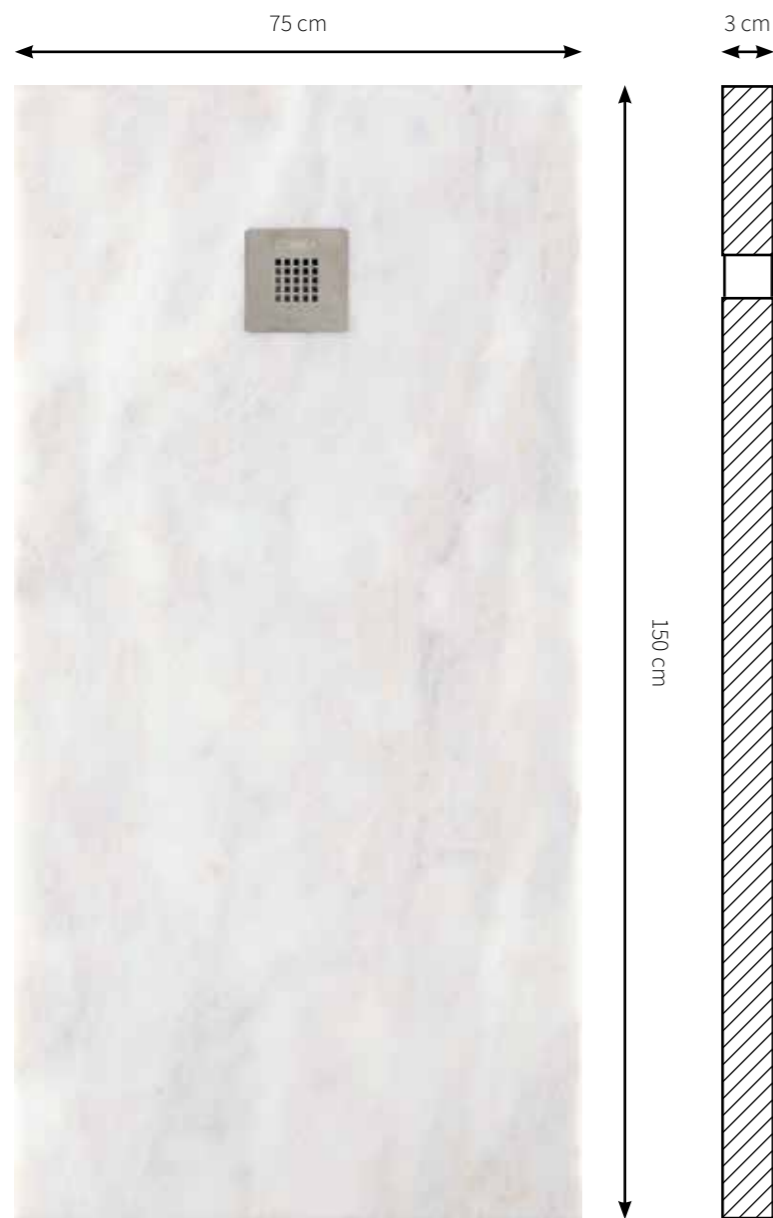

SINGULAR BLANCO PL 75x150x3

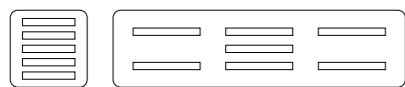

All the grids in Singular collection are available in the same finish as the tray.  
*Todos los platos Singular disponen de la opción de la rejilla en el mismo acabado que el plato.*

All the Singular trays are available with BR, CA, PL y TR finishes.  
Stand measures wide 70 to 100, length 80 to 200. Also made to measure.

*Todos los platos Singular están disponibles con los acabados BR, CA, PL y TR.  
Todos los platos Singular se fabrican en medidas estándar de ancho 70-100cm y largo de 80-200cm. También en medida personalizada.*





# SINGULAR

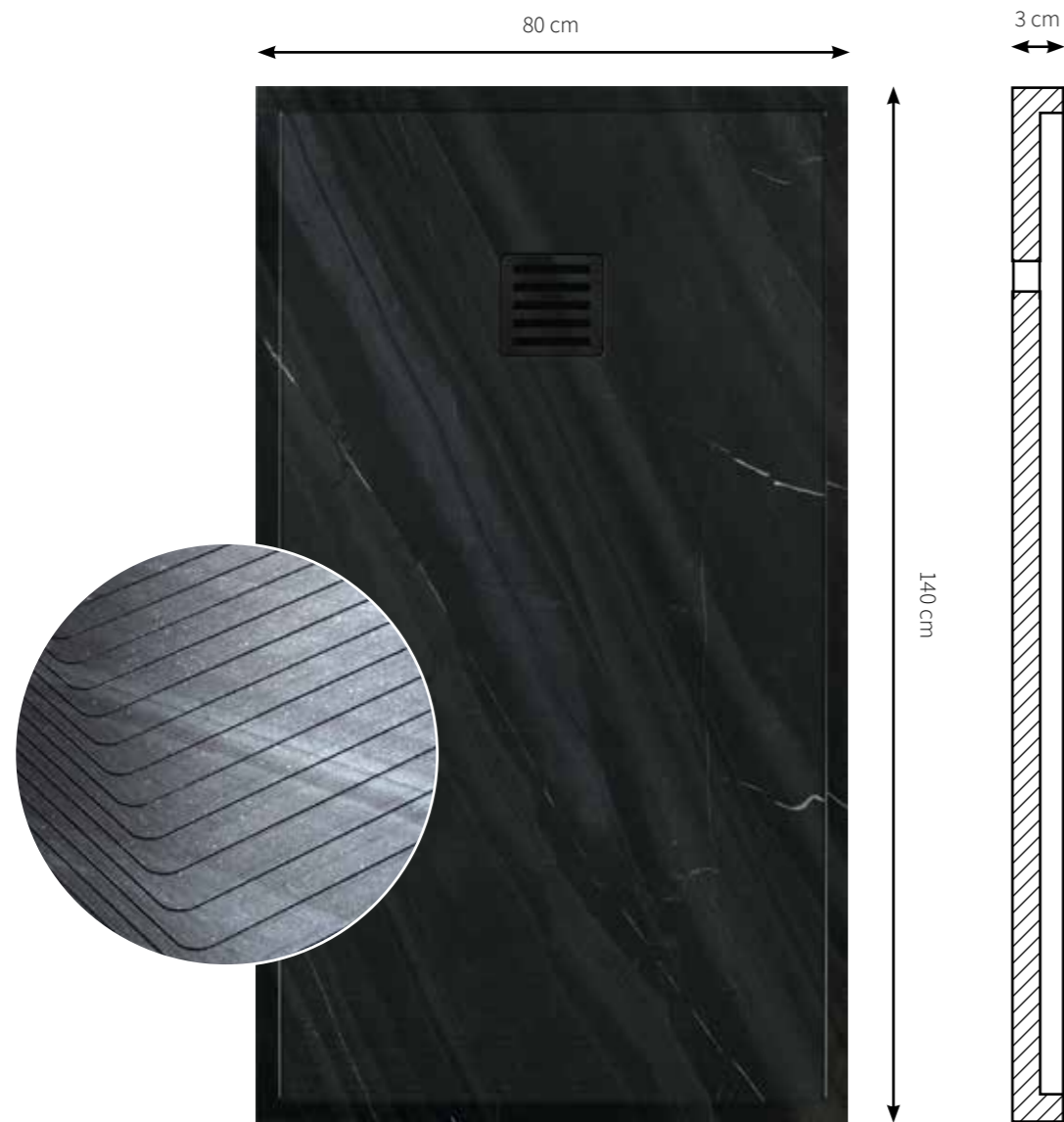

SINGULAR NEGRO BR TR 90x120x3

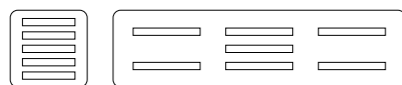

All the grids in Singular collection are available in the same finish as the tray.  
*Todos los platos Singular disponen de la opción de la rejilla en el mismo acabado que el plato.*

All the Singular trays are available with BR, CA, PL y TR finishes.  
 Stand measures wide 70 to 100, length 80 to 200. Also made to measure.

*Todos los platos Singular están disponibles con los acabados BR, CA, PL y TR.  
 Todos los platos Singular se fabrican en medidas estándar de ancho 70-100cm y largo de 80-200cm.  
 También en medida personalizada.*

## CONFIGURATION

Singular offers 5 different configuration according to:  
 A. Type of surface.  
 B. Plate dimensions.  
 C. Type of drain.  
 D. Glass or screen location.  
 E. Location of the plate with respect to the ground.

## CONFIGURACIÓN

Singular ofrece 5 niveles de configuración atendiendo a:  
 A. Tipo de superficie.  
 B. Dimensiones del plato.  
 C. Tipo de desagüe.  
 D. Ubicación de cristal o mampara.  
 E. Ubicación del plato con respecto al suelo.

### A.

All the Singular trays are available with BR, CA, PL y TR finishes.

*Todos los platos Singular están disponibles en los acabados BR, CA, TR, PL.*

BR. Reduced edge.  
 BR. Borde rebajado.

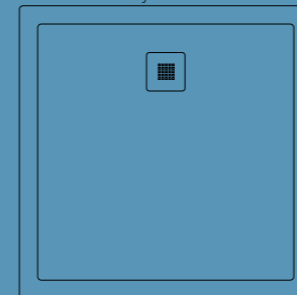

CA. Fall from zero.  
 CA. Caída desde cero.

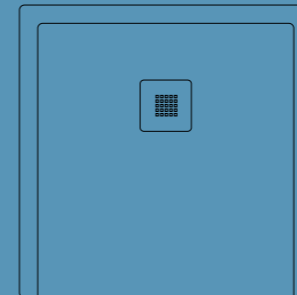

PL. Flat.  
 PL. Plano.

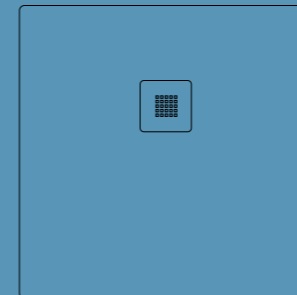

TR. Triangular Striped.  
 TR. Triangular Rayado.

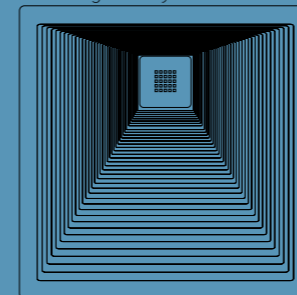

### B.

Stand measures wide 70 to 100, length 80 to 200. Also made to measure.

*Las medidas disponibles van desde los 70 a los 100 cm de ancho y de los 70 a los 200 de largo (a intervalos de 10 cm).  
 Además se fabrica a medida y con escotes personalizados.*

X. 70/80/90/100  
 Y. 70/80/90/100/110.../200

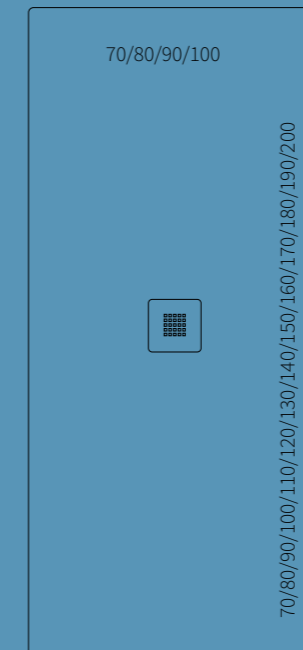

### C.

Drain and also waste may vary location. It can be CU or TR.

*La ubicación del desagüe también puede variar y el tipo de rejilla puede ser CU o TR.*

CU:

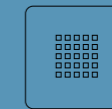

TR:



OPTIONAL: the grid can be the same material as the tray (see previous page).

OPCIONAL: La rejilla puede ser del mismo material que el plato (ver pág. anterior).



### D.

Glass can be located in three different ways:

*El cristal se puede ubicar de tres forma distintas:*

A. On the shower tray.  
 Sobre el plato.



B. Next to the shower tray.  
 Junto al plato.



C. Joined with shower tray.  
 Encastrado.



### E.

Shower trays have three different options of placement with respect to the ground.

*Los platos tienen tres opciones de colocación con respecto al suelo.*

A. Surface-fitted.  
 Sobre el suelo.



B. Flush Fitting.  
 A ras de suelo.

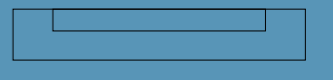

C. Raised or semi-flush.  
 Elevado.

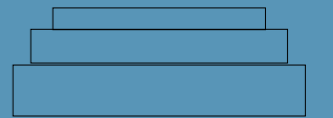

# FINE

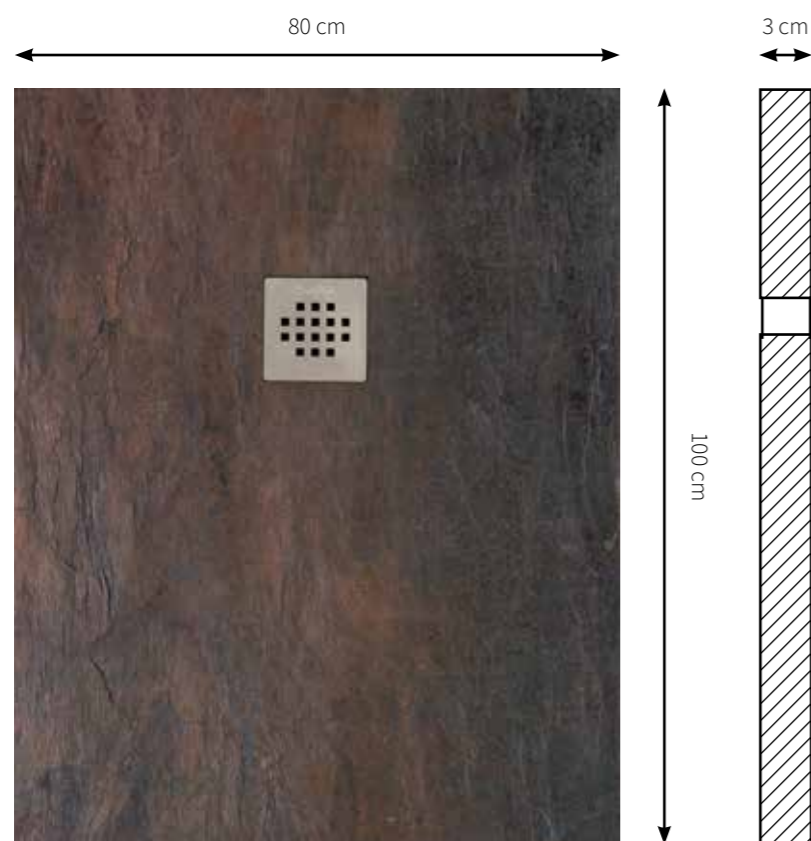

FINE 03 80x100x3

All the Fine trays are only available in PL finish.  
Stand measures wide 70 to 100, length 80 to 200. Also made to measure.

*Todos los platos Fine están disponibles únicamente con el acabado PL.  
Todos los platos Fine se fabrican en medidas estándar de ancho 70-100cm y largo de 80-200cm. También en medida personalizada.*

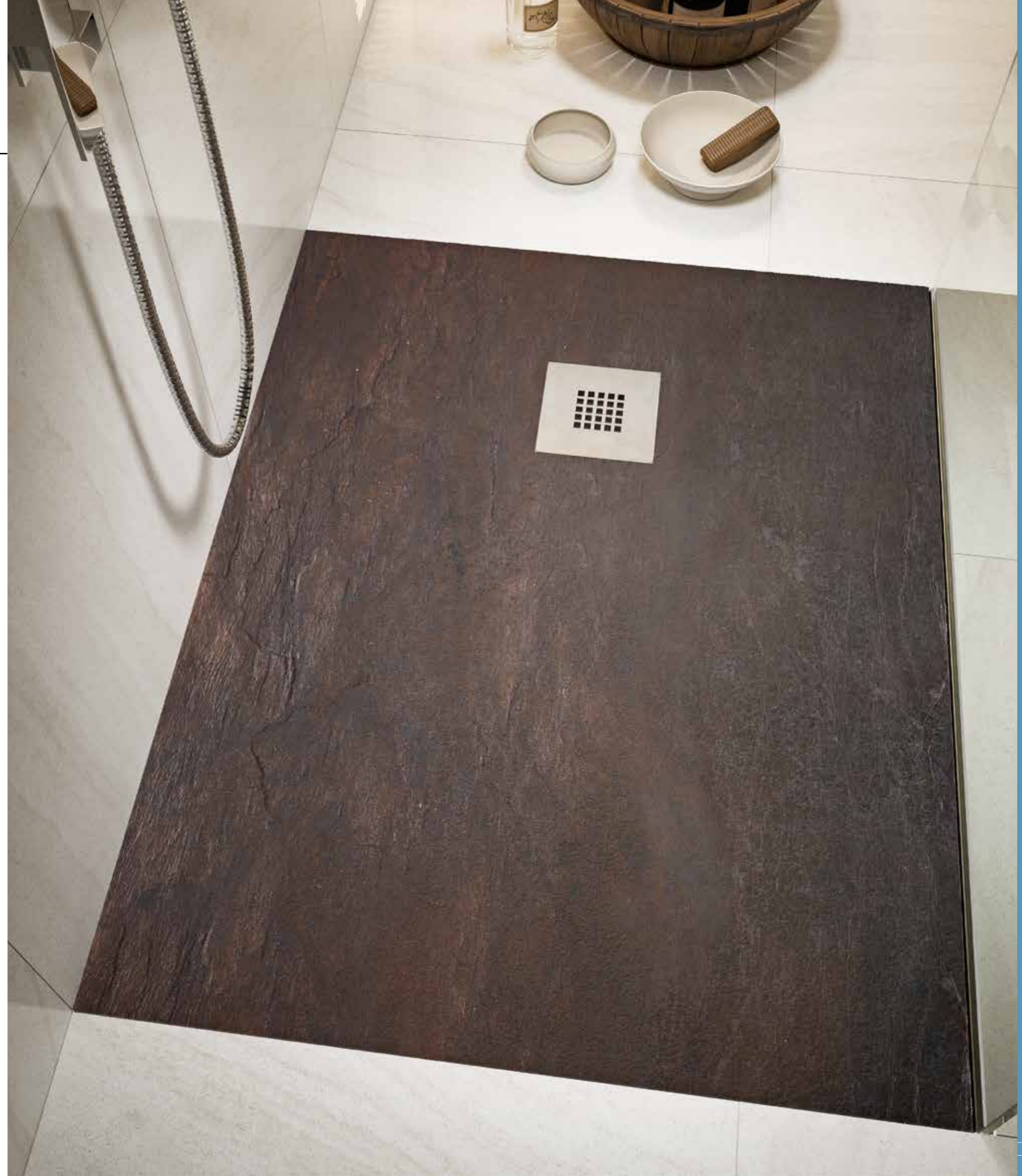

# FINE

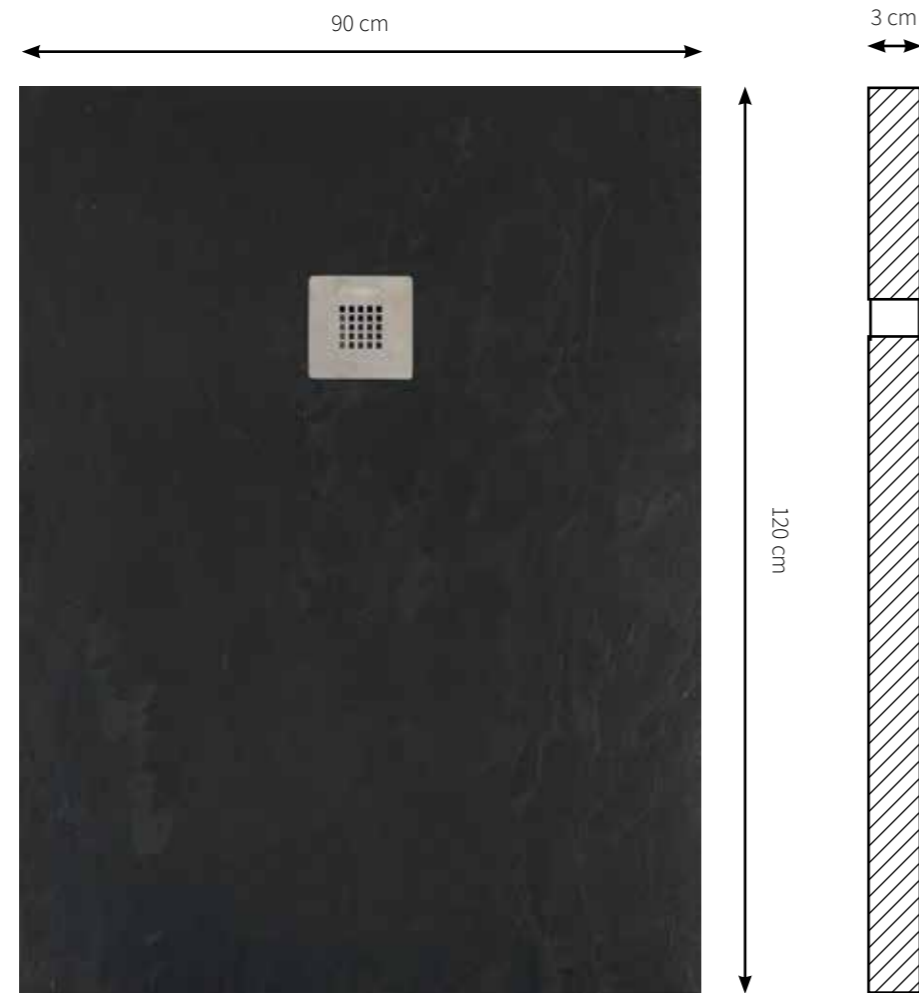

**FINE 01** 90x120x3

All the Fine trays are only available in PL finish.  
Stand measures wide 70 to 100, length 80 to 200. Also made to measure.

*Todos los platos Fine están disponibles únicamente con el acabado PL.  
Todos los platos Fine se fabrican en medidas estándar de ancho 70-100cm y largo de 80-200cm. También en medida personalizada.*

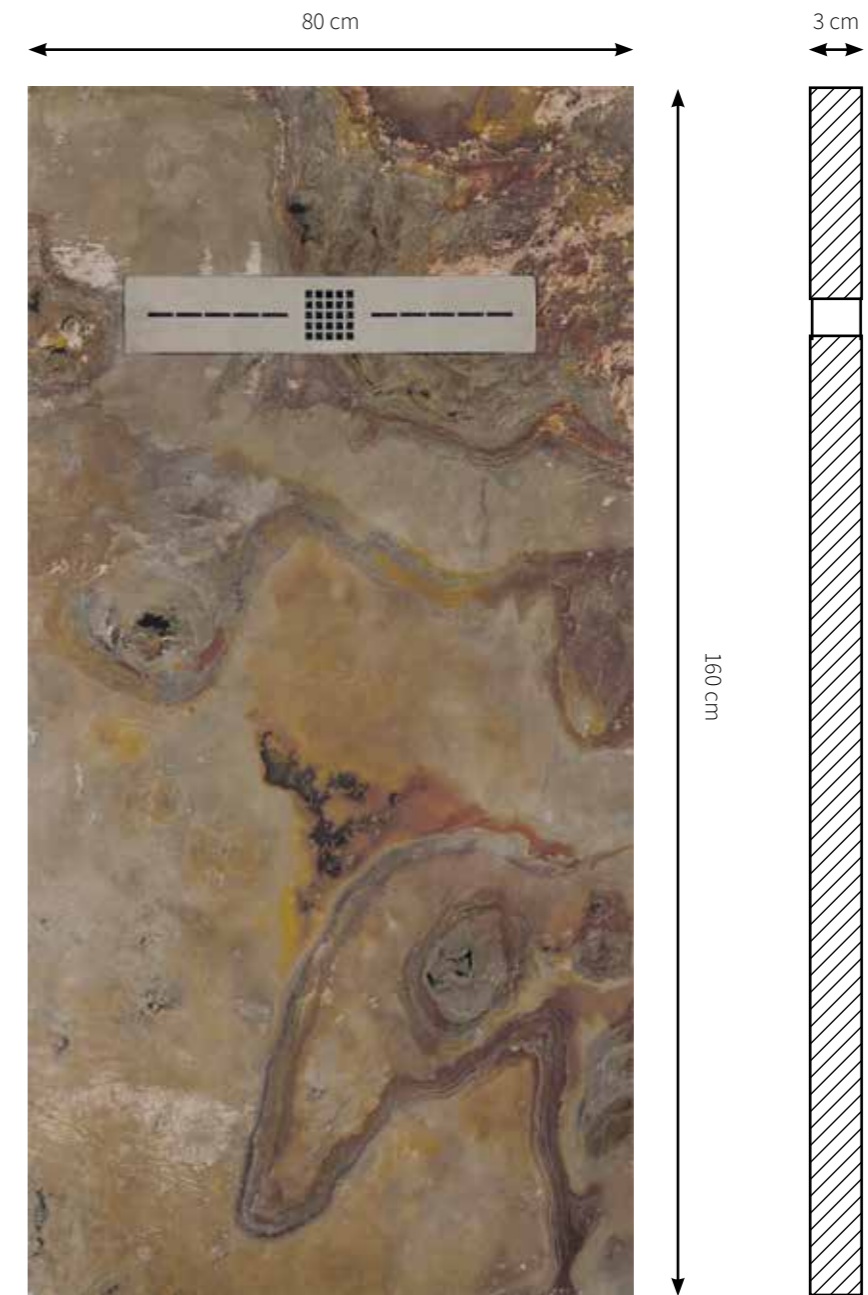

**FINE 04** 80x160x3

All the Fine trays are only available in PL finish.  
Stand measures wide 70 to 100, length 80 to 200. Also made to measure.

*Todos los platos Fine están disponibles únicamente con el acabado PL.  
Todos los platos Fine se fabrican en medidas estándar de ancho 70-100cm y largo de 80-200cm. También en medida personalizada.*

# FINE

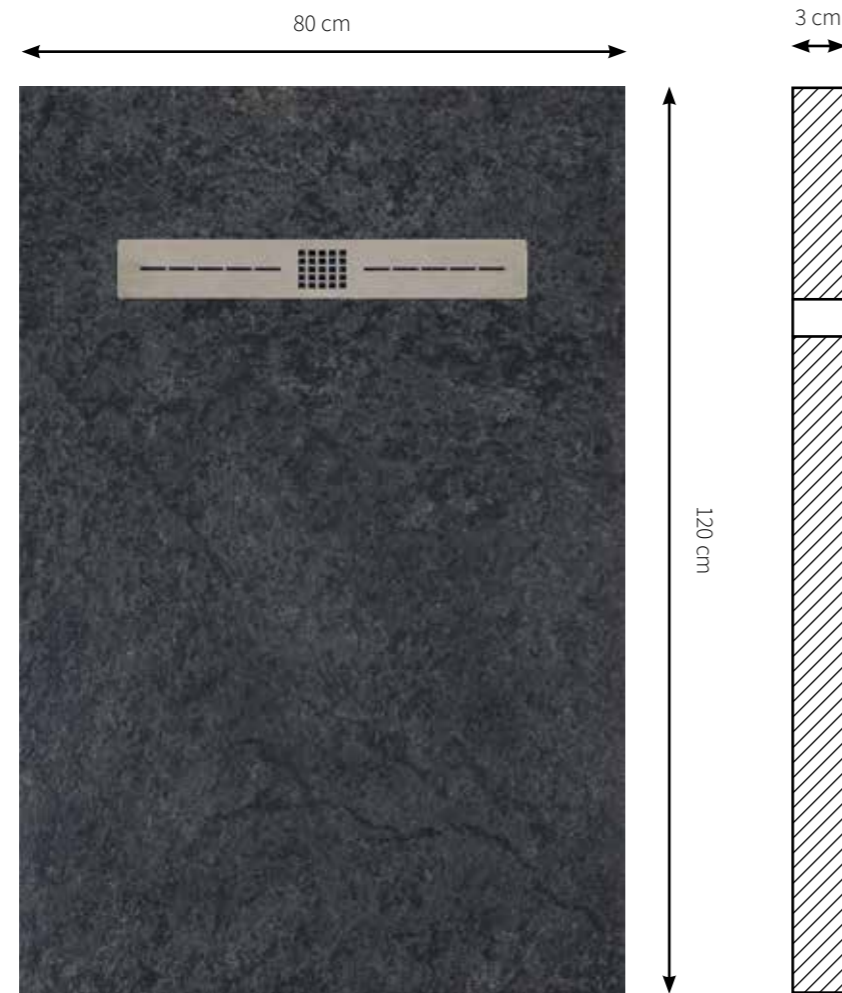

**FINE 05** 80x120x3

All the Fine trays are only available in PL finish.  
Stand measures wide 70 to 100, length 80 to 200. Also made to measure.

*Todos los platos Fine están disponibles únicamente con el acabado PL.  
Todos los platos Fine se fabrican en medidas estándar de ancho 70-100cm y largo de 80-200cm. También en medida personalizada.*

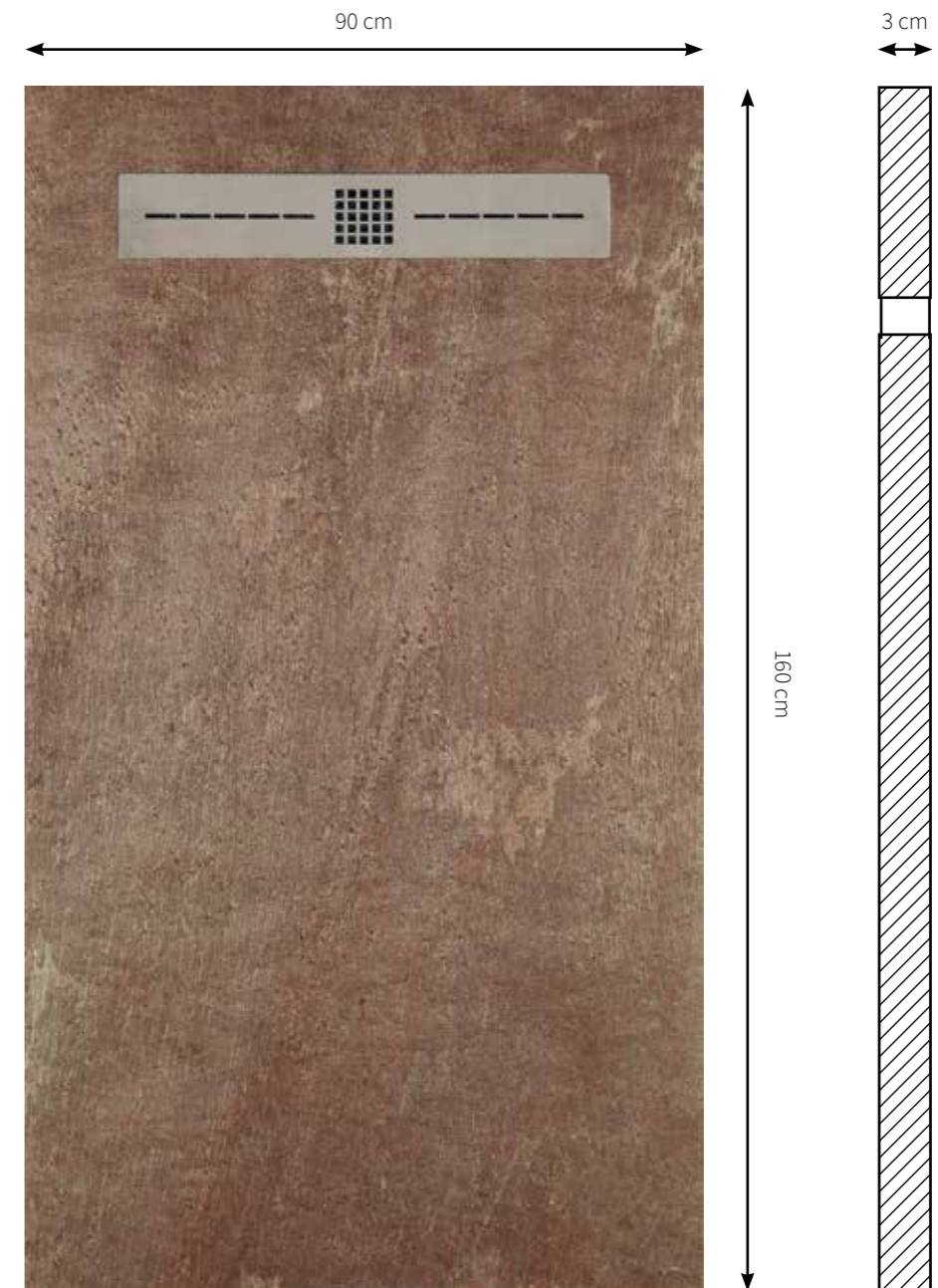

**FINE 08** 90x160x3

All the Fine trays are only available in PL finish.  
Stand measures wide 70 to 100, length 80 to 200. Also made to measure.

*Todos los platos Fine están disponibles únicamente con el acabado PL.  
Todos los platos Fine se fabrican en medidas estándar de ancho 70-100cm y largo de 80-200cm. También en medida personalizada.*

# FINE



FINE 07 90x160x3

All the Fine trays are only available in PL finish.  
Stand measures wide 70 to 100, length 80 to 200. Also made to measure.

*Todos los platos Fine están disponibles únicamente con el acabado PL.  
Todos los platos Fine se fabrican en medidas estándar de ancho 70-100cm y largo de 80-200cm. También en medida personalizada.*



# FINE

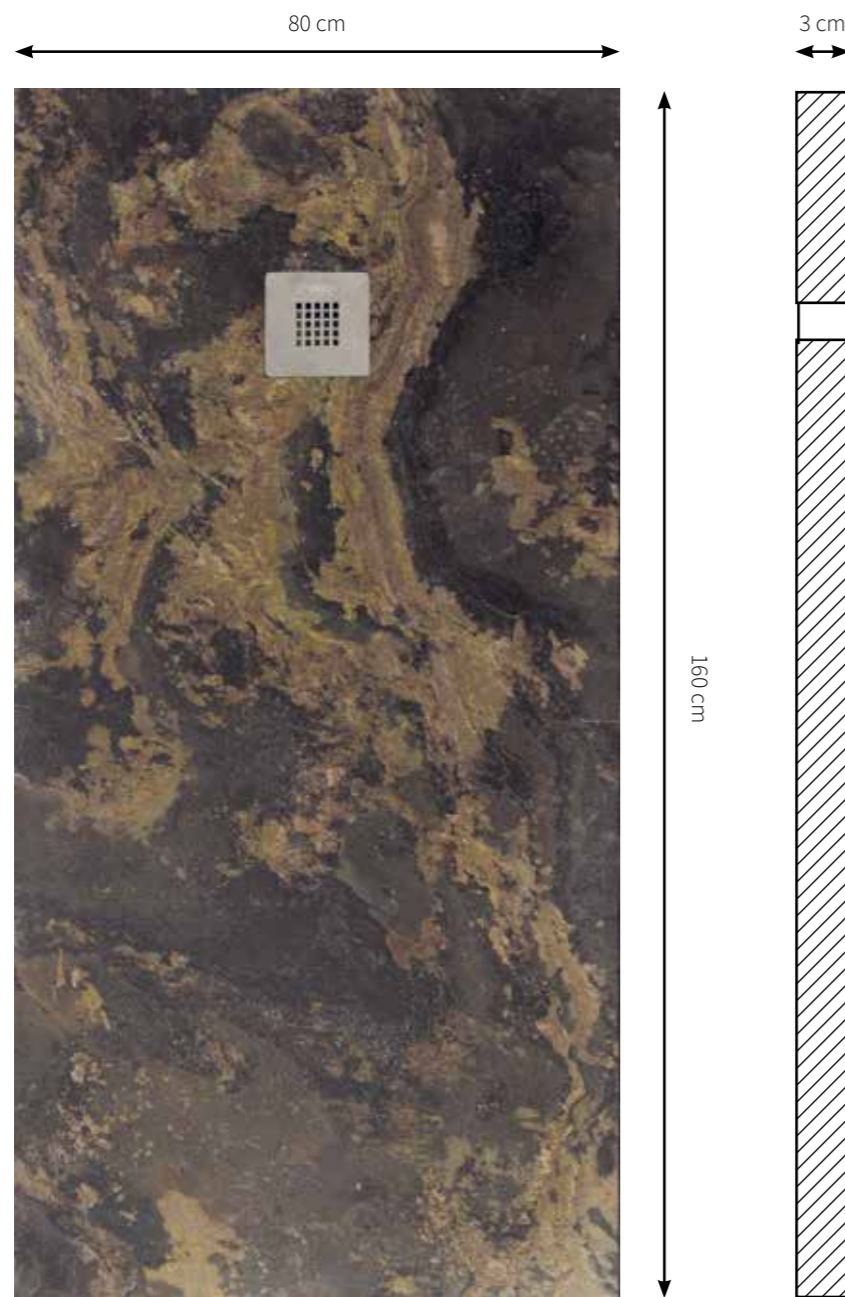

**FINE 14** 80x160x3

All the Fine trays are only available in PL finish.  
Stand measures wide 70 to 100, length 80 to 200. Also made to measure.

*Todos los platos Fine están disponibles únicamente con el acabado PL.  
Todos los platos Fine se fabrican en medidas estándar de ancho 70-100cm y largo de 80-200cm. También en medida personalizada.*

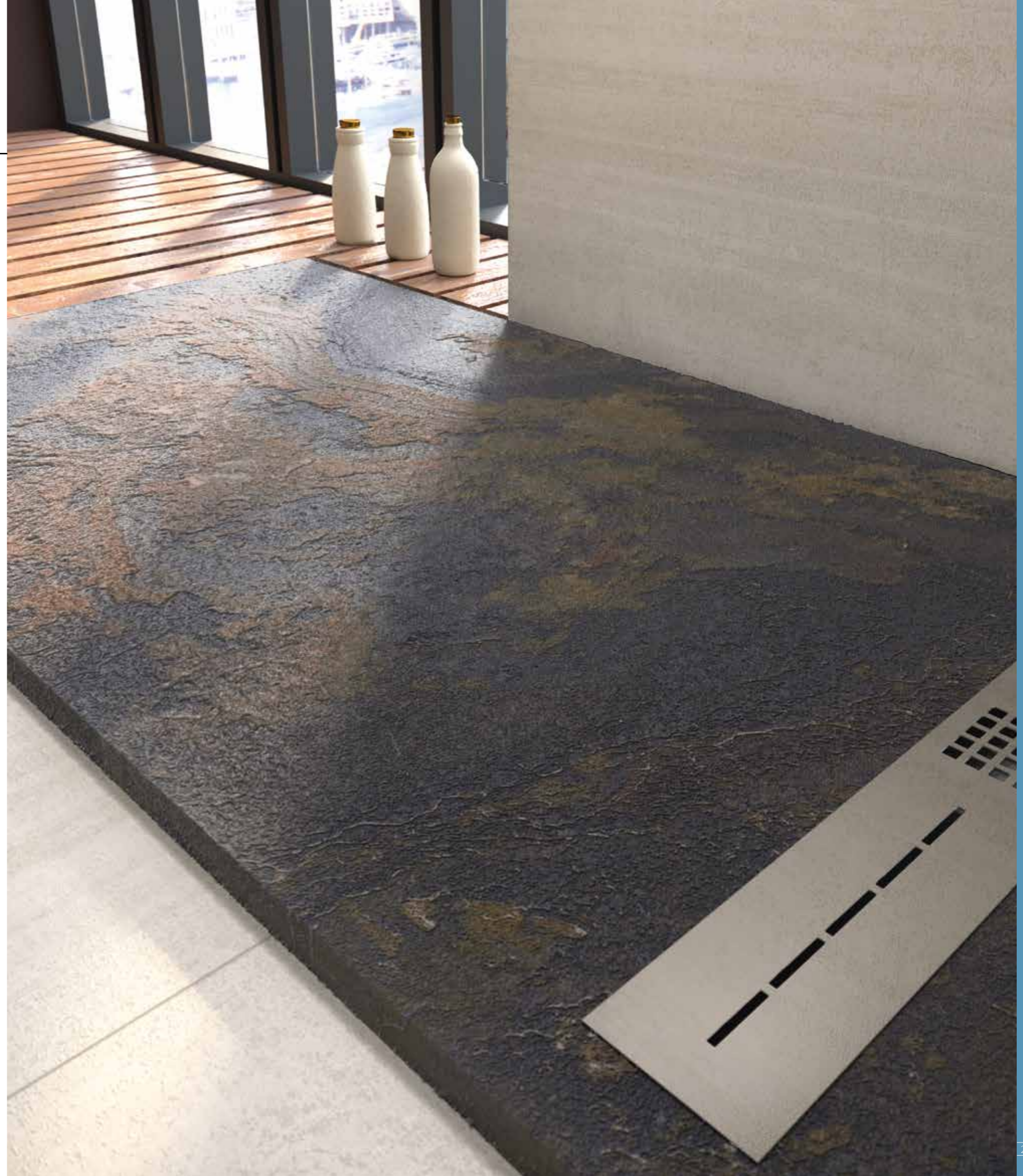

# FINE

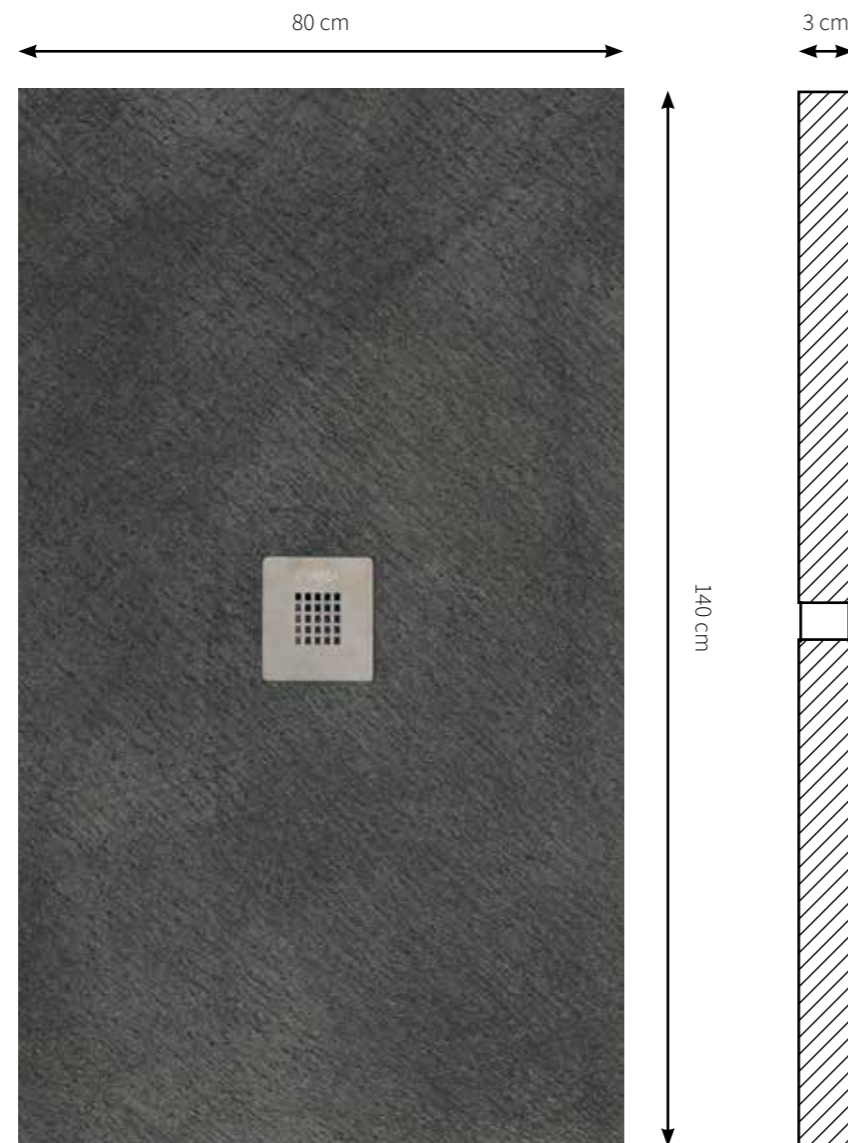

FINE 09 80x140x3

All the Fine trays are only available in PL finish.  
Stand measures wide 70 to 100, length 80 to 200. Also made to measure.

*Todos los platos Fine están disponibles únicamente con el acabado PL.  
Todos los platos Fine se fabrican en medidas estándar de ancho 70-100cm y largo de 80-200cm. También en medida personalizada.*

## CONFIGURATION

Fine offers 5 different configuration according to:  
A. Type of surface.  
B. Plate dimensions.  
C. Type of drain.  
D. Glass or screen location.  
E. Location of the plate with respect to the ground.

## CONFIGURACIÓN

Fine ofrece 5 niveles de configuración atendiendo a:  
A. Acabado del plato.  
B. Dimensiones del plato.  
C. Tipo de desagüe.  
D. Ubicación de cristal o mampara.  
E. Ubicación del plato con respecto al suelo.

### A.

Fine shower trays are manufactured with Flexitone®, natural stone with a resin plate. It can be served with the edges seen or lined at an angle, available in BR finishes, CA, TR, PL.

*Los platos Fine están fabricados con Flexitone®, lámina de piedra natural, sobre plancha de resina. Se puede servir con los cantos vistos o forrado en ángulo, disponibles en los acabados BR, CA, TR, PL.*

A. Flexitone® on resin.  
*Flexitone® sobre resina.*

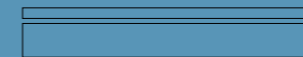

B. Edged Flexitone®.  
*Flexitone® canteado.*



### B.

Stand measures wide 70 to 100, length 80 to 200. Also made to measure.

*Las medidas disponibles van desde los 70 a los 100 cm de ancho y de los 70 a los 200 de largo (a intervalos de 10 cm). Además se fabrica a medida y con escotes personalizados.*

X. 70/80/90/100  
Y. 70/80/90/100/110.../200

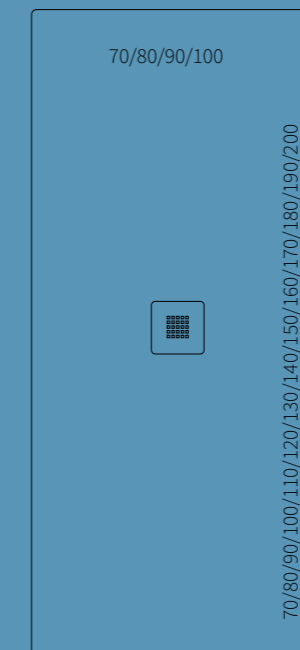

### C.

Drain and also waste may vary location. It can be CU or TR.

*La ubicación del desagüe también puede variar y el tipo de rejilla puede ser CU o TR.*

CU:



TR:



### D.

Glass can be located in three different ways:

*El cristal se puede ubicar de tres forma distintas:*

A. On the shower tray.  
*Sobre el plato.*



B. Next to the shower tray.  
*Junto al plato.*



C. Joined with shower tray.  
*Encastrado.*



### E.

Shower trays have three different options of placement with respect to the ground.

*Los platos tienen tres opciones de colocación con respecto al suelo.*

A. Surface-fitted.  
*Sobre el suelo.*



B. Flush Fitting.  
*A ras de suelo.*

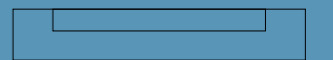

C. Raised or semi-flush.  
*Elevado.*



# ARQUITECT

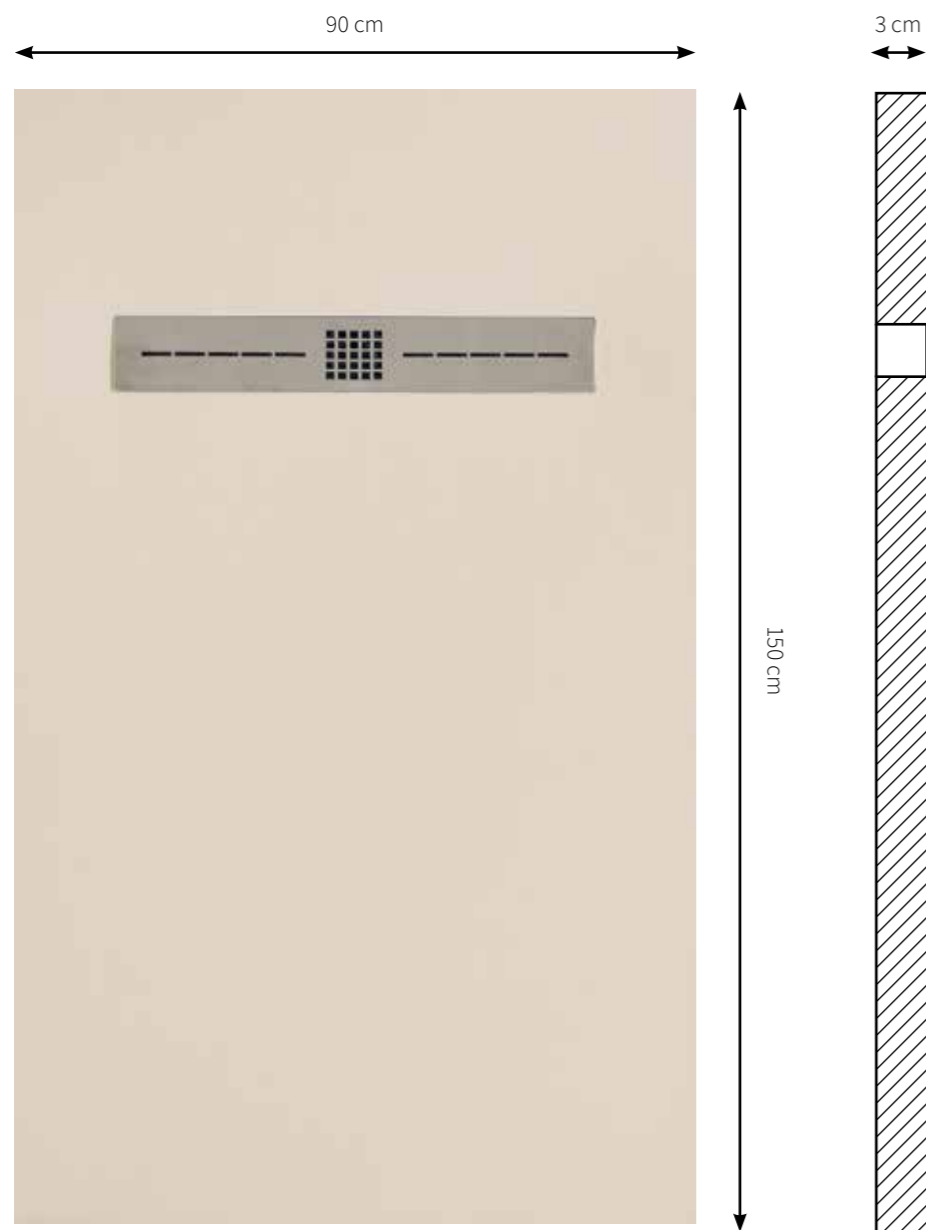

ARQUITECT BEIGE 90x150x3



Piel Beige Piel Negro Piel Mostaza Piel Gris

The Arquitect trays are available in 4 different colours and PL finish. Stand measures wide 70 to 100, length 80 to 200. Also made to measure.

*Los platos Arquitect están disponibles únicamente con el acabado PL y en 4 colores. Todos los platos Arquitect se fabrican en medidas estándar de ancho 70-100cm y largo de 80-200cm. También en medida personalizada.*





# ARQUITECT

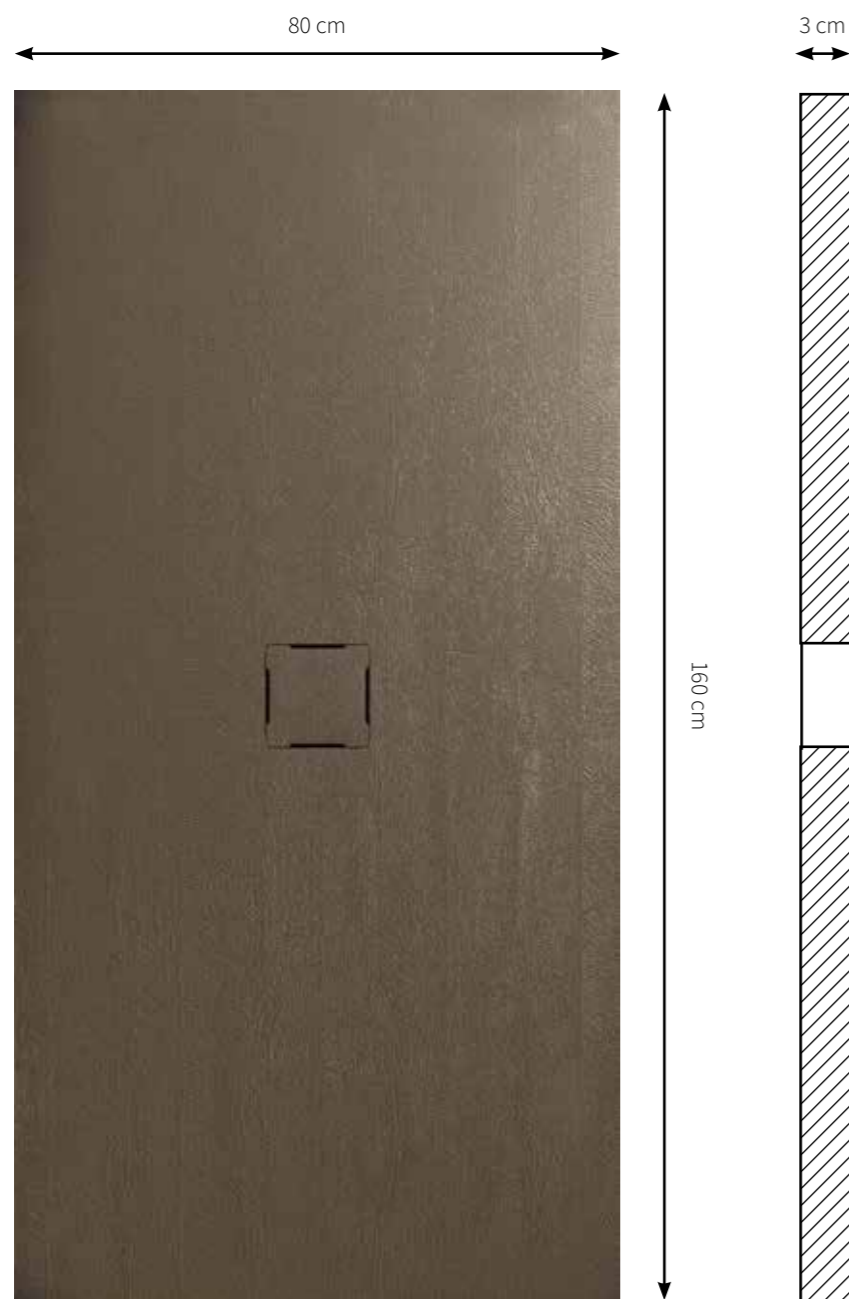

ARQUITECT WOOD 80x160x3

The Arquitect Wood tray are available in 1 colour and PL finish.  
Stand measures wide 70 to 100, length 80 to 200. Also made to measure.

*El plato Arquitect Wood está disponible únicamente con el acabado PL y en 1 color.  
Todos los platos Arquitect se fabrican en medidas estándar de ancho 70-100cm y largo de 80-200cm. También en medida personalizada.*

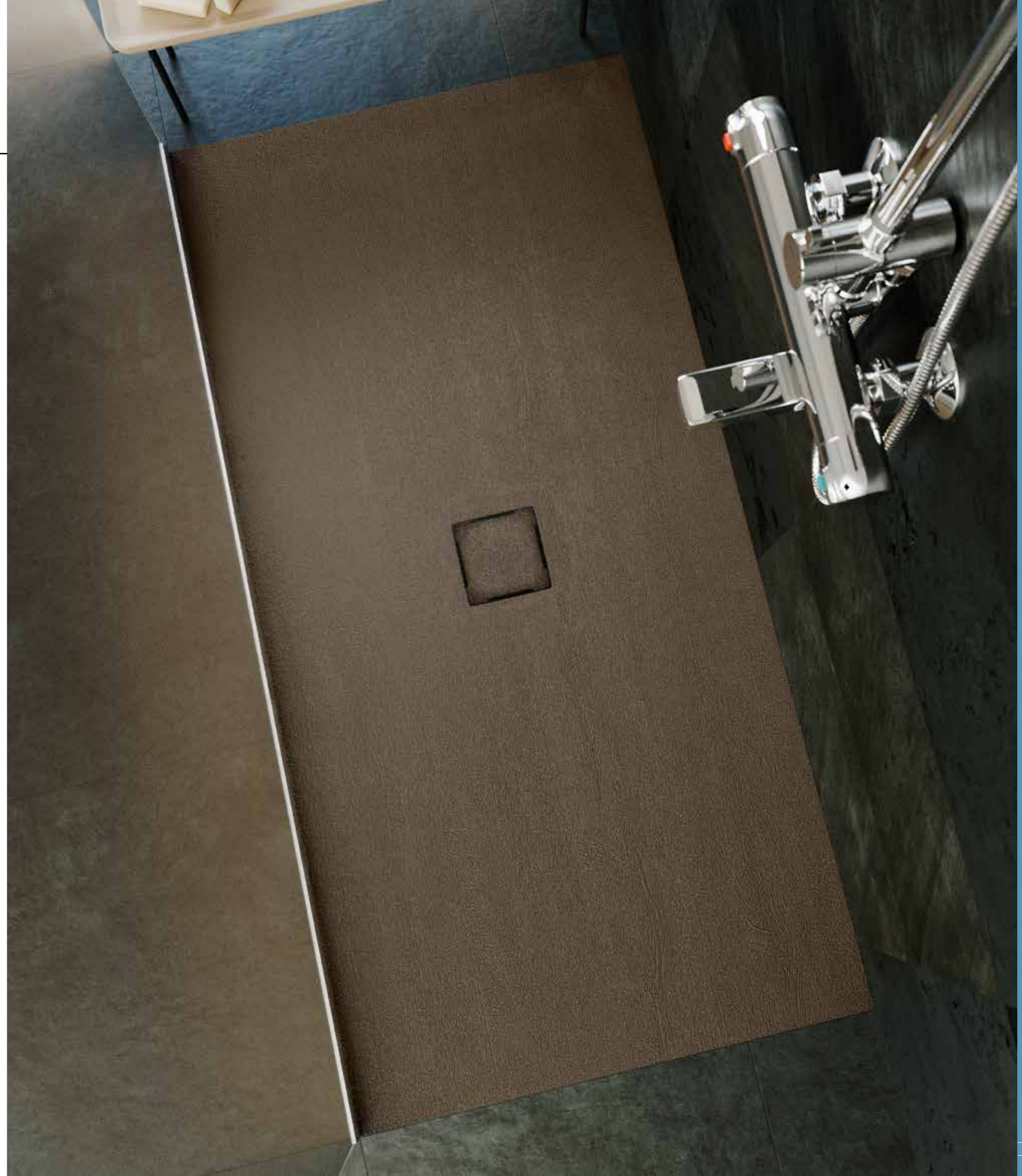

# ARQUITECT



ARQUITECT MOSAIC GRIS 80x180x3

The Arquitect Mosaic trays are available in 4 different colours and PL finish. Stand measures wide 70 to 100, length 80 to 200. Also made to measure.

*Los platos Arquitect Mosaic están disponibles únicamente con el acabado PL y en 4 colores. Todos los platos Arquitect se fabrican en medidas estándar de ancho 70-100cm y largo de 80-200cm. También en medida personalizada.*

## CONFIGURATION

Arquitect offers 4 different configuration according to:  
 A. Plate dimensions.  
 B. Type of drain.  
 C. Glass or screen location.  
 D. Location of the plate with respect to the ground.

## CONFIGURACIÓN

Arquitect ofrece 4 niveles de configuración atendiendo a:  
 A. Dimensiones del plato.  
 B. Tipo de desagüe.  
 C. Ubicación de cristal o mampara.  
 D. Ubicación del plato con respecto al suelo.

### A.

Stand measures wide 70 to 100, length 80 to 200. Also made to measure.

*Las medidas disponibles van desde los 70 a los 100 cm de ancho y de los 70 a los 200 de largo (a intervalos de 10 cm). Además se fabrica a medida y con escotes personalizados.*

X. 70/80/90/100  
 Y. 70/80/90/100/110.../200

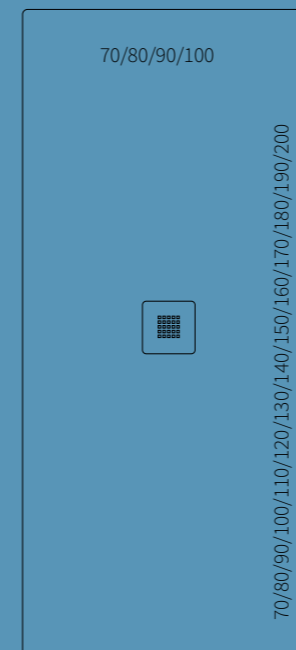

### B.

Drain and also waste may vary location. It can be CU or TR.

*La ubicación del desagüe también puede variar y el tipo de rejilla puede ser CU o TR.*

CU:

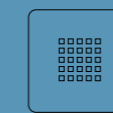

TR:

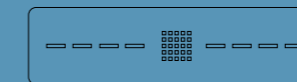

### C.

Glass can be located in three different ways:

*El cristal se puede ubicar de tres forma distintas:*

A. On the shower tray.  
*Sobre el plato.*



B. Next to the shower tray.  
*Junto al plato.*



### D.

Shower trays have three different options of placement with respect to the ground.

*Los platos tienen tres opciones de colocación con respecto al suelo.*

A. Surface-fitted.  
*Sobre el suelo.*

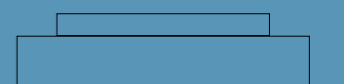

B. Flush Fitting.  
*A ras de suelo.*

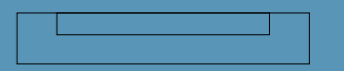

C. Raised or semi-flush.  
*Elevado.*



# RIN

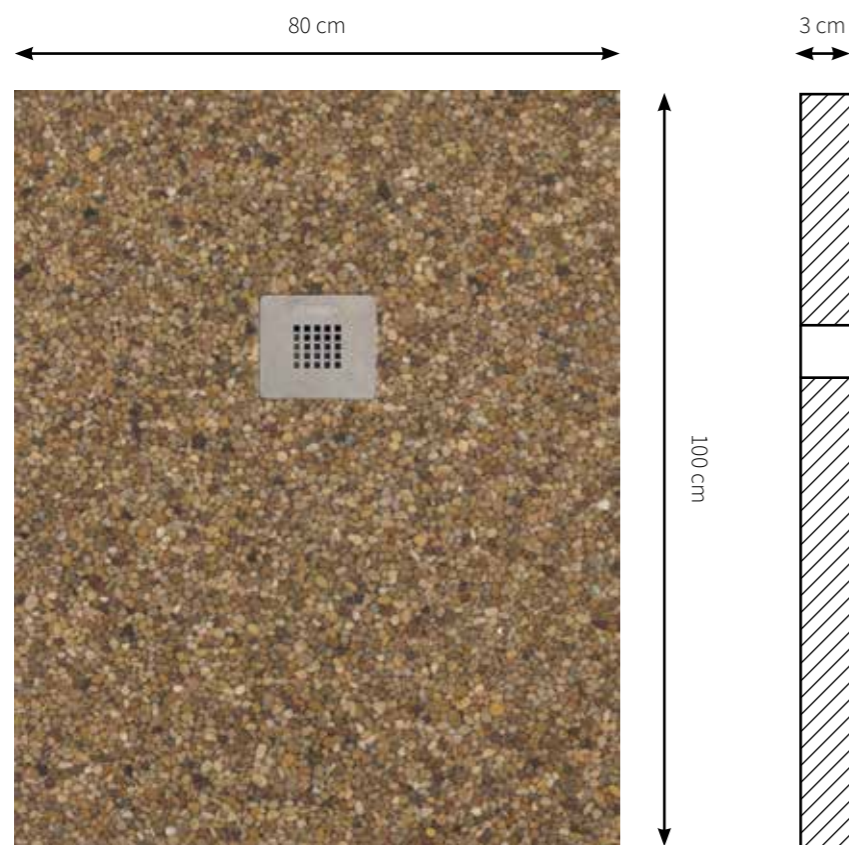

RIN MARRON 80x100x3

All the Rin trays are available in 2 different colours and PL finish.  
Stand measures wide 70 to 100, length 80 to 200. Also made to measure.

*Todos los platos Rin están disponibles únicamente en acabados PL y en 2 colores.  
Todos los platos Rin se fabrican en medidas estándar de ancho 70-100cm y largo de 80-200cm. También en medida personalizada.*



# RIN

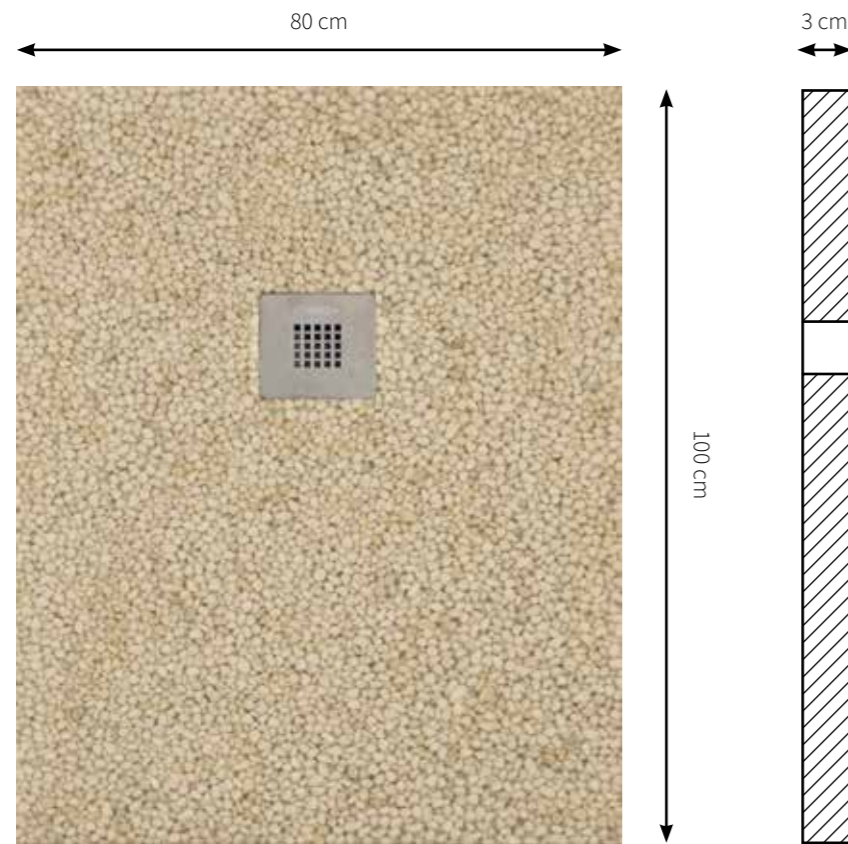

RIN BEIGE 80x1000x3

All the Rin trays are available in 2 different colours and PL finish. Stand measures wide 70 to 100, length 80 to 200. Also made to measure.

*Todos los platos Rin están disponibles únicamente en acabados PL y en 2 colores. Todos los platos Rin se fabrican en medidas estándar de ancho 70-100cm y largo de 80-200cm. También en medida personalizada.*

## CONFIGURATION

Rin offers 4 different configuration according to:  
 A. Plate dimensions.  
 B. Type of drain.  
 C. Glass or screen location.  
 D. Location of the plate with respect to the ground.

## CONFIGURACIÓN

Rin ofrece 4 niveles de configuración atendiendo a:  
 A. Dimensiones del plato.  
 B. Tipo de desagüe.  
 C. Ubicación de cristal o mampara.  
 D. Ubicación del plato con respecto al suelo.

### A.

Stand measures wide 70 to 100, length 80 to 200. Also made to measure.

*Las medidas disponibles van desde los 70 a los 100 cm de ancho y de los 70 a los 200 de largo (a intervalos de 10 cm). Además se fabrica a medida y con escotes personalizados.*

X. 70/80/90/100  
 Y. 70/80/90/100/110.../200

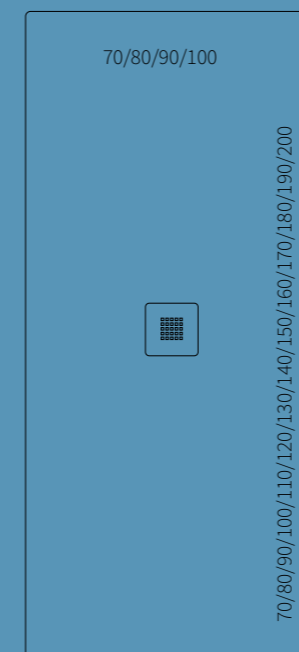

### B.

Drain and also waste may vary location. It can be CU or TR.

*La ubicación del desagüe también puede variar y el tipo de rejilla puede ser CU o TR.*

CU:

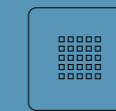

TR:



### C.

Glass can be located in three different ways:

*El cristal se puede ubicar de tres forma distintas:*

A. On the shower tray.  
*Sobre el plato.*



B. Next to the shower tray.  
*Junto al plato.*



### D.

Shower trays have three different options of placement with respect to the ground.

*Los platos tienen tres opciones de colocación con respecto al suelo.*

A. Surface-fitted.  
*Sobre el suelo.*

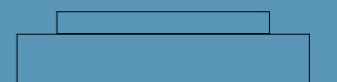

B. Flush Fitting.  
*A ras de suelo.*

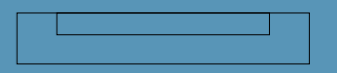

C. Raised or semi-flush.  
*Elevado.*



# MT100

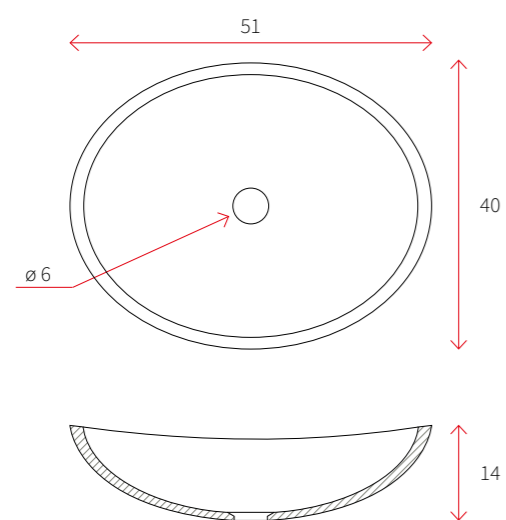

# MT101

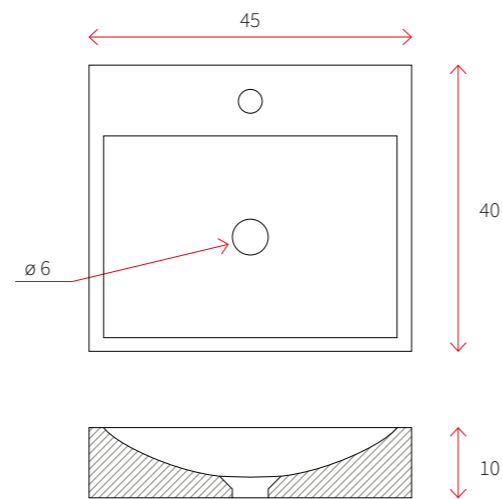

# MT102

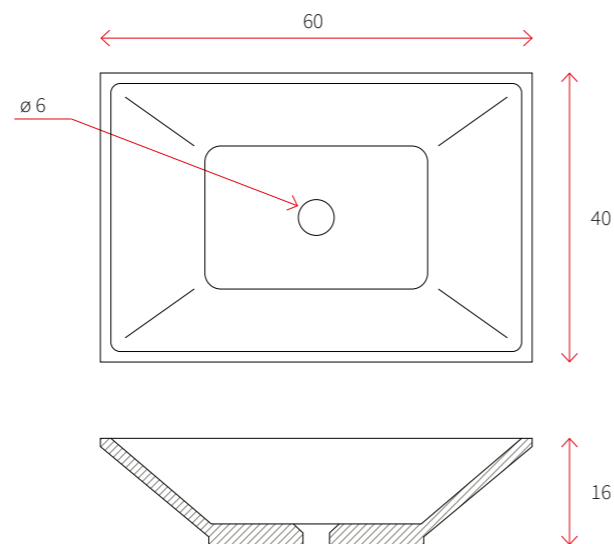

# SP19

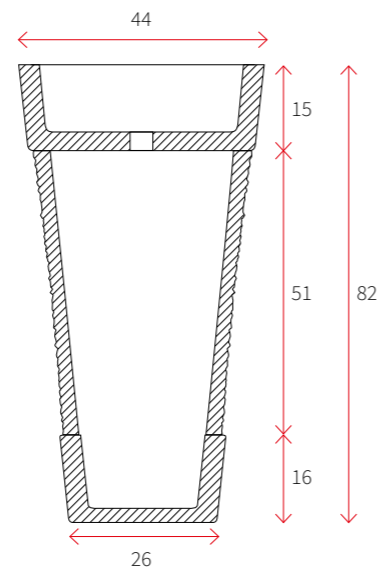

# BLACK OVAL

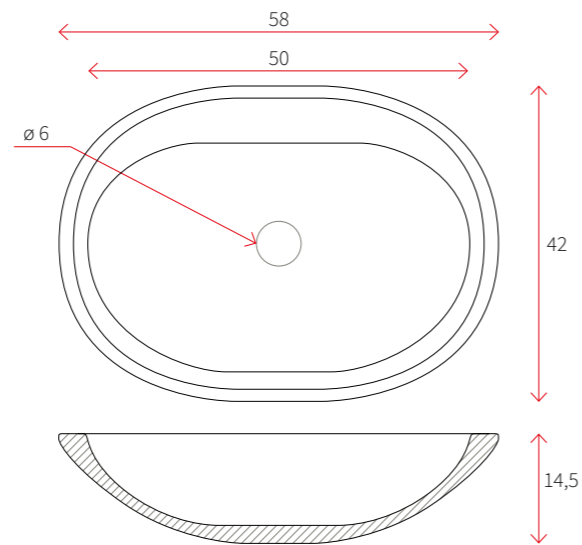

# RS47

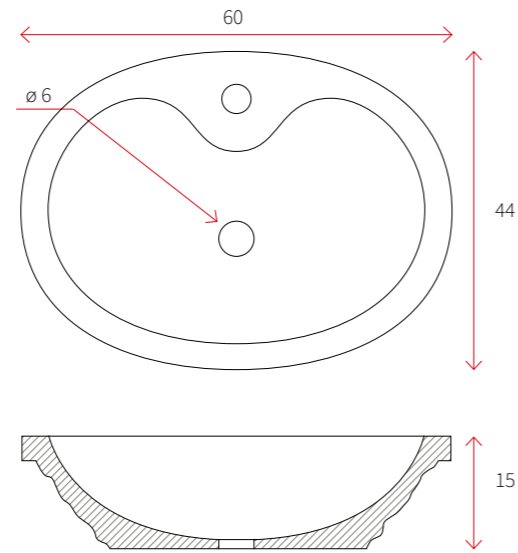

# RS37

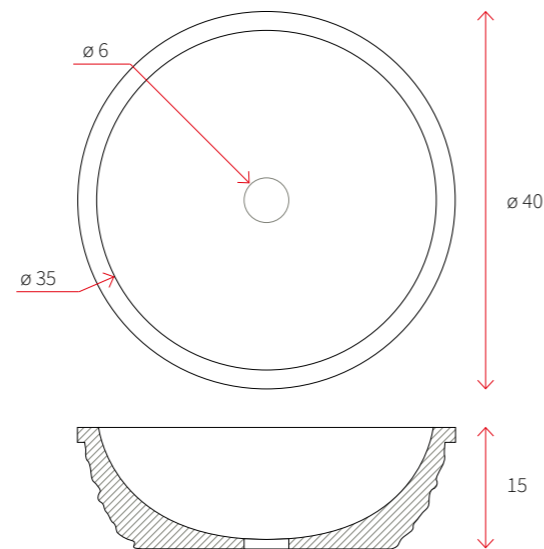



# RS48

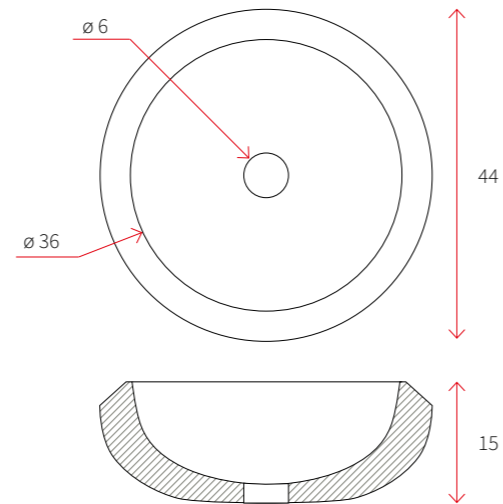

# RS32

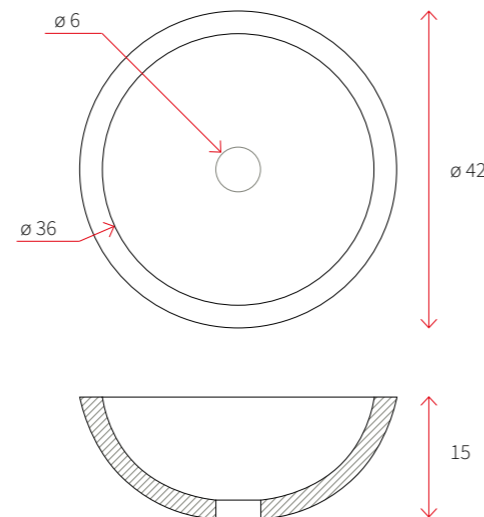

# RS35

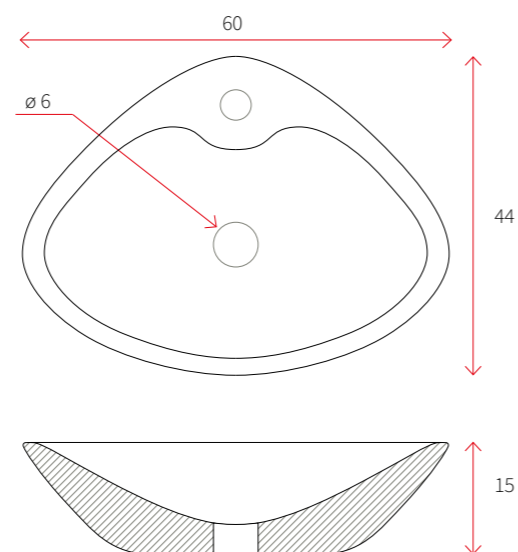

# SS19

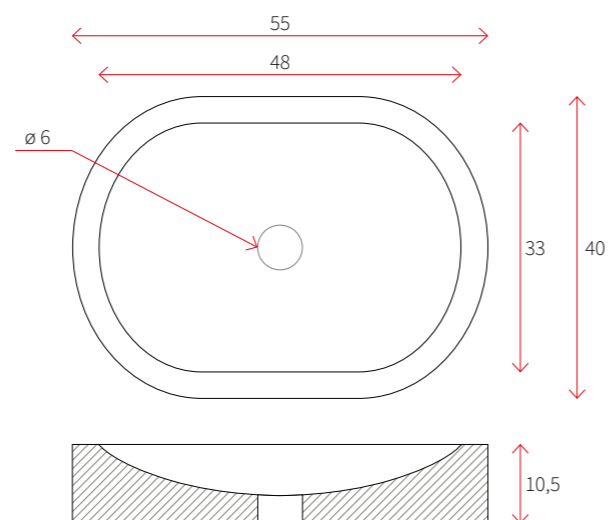

SP18

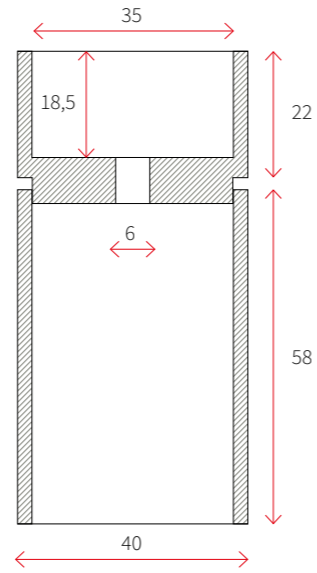

NANTES

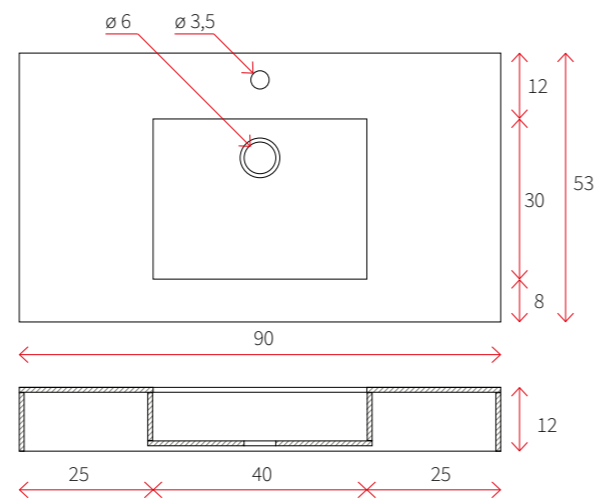

YAKARTA

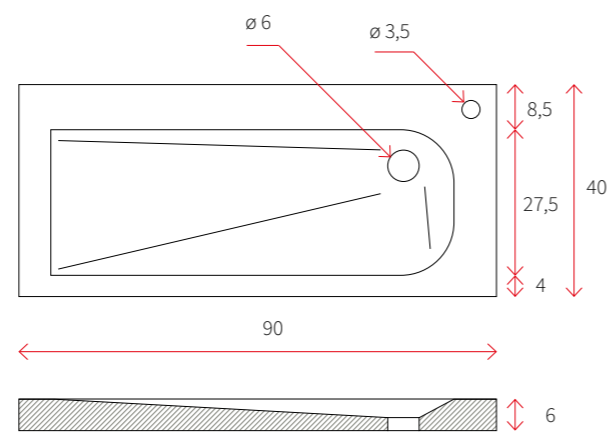

RS23

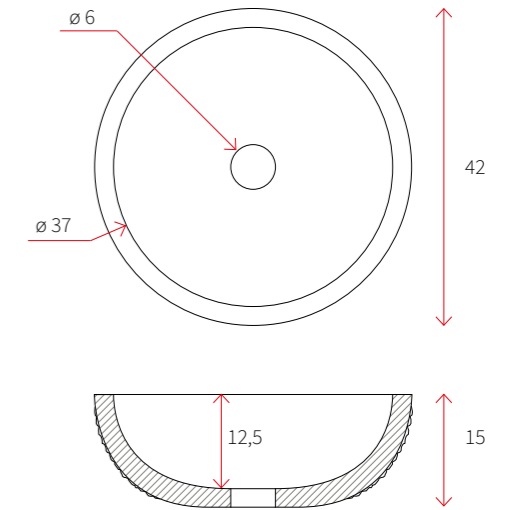

RS53

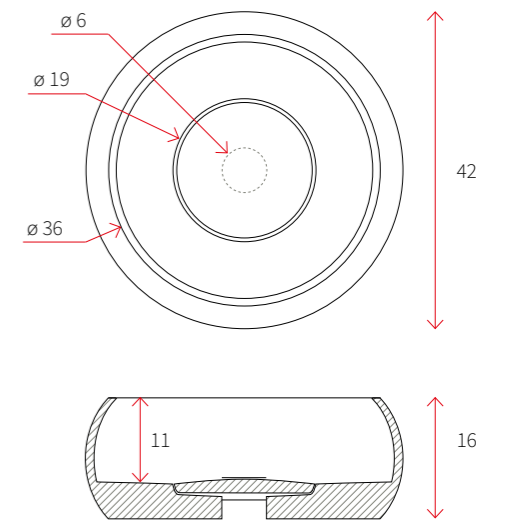

ZEN

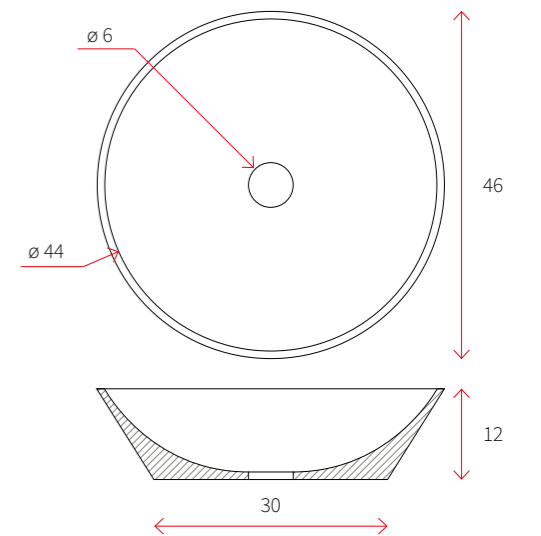

## 1. GENERAL CONDITIONS AND GUARANTEES

ONAREA® guarantees its products and components against any lack of conformity only when they have been correctly fitted and used. The company shall not be responsible for any claims derived from problems arising due to incorrect fitting or use of the products, and will hereby not be liable for any extraordinary costs such as the replacement of shower screen, tiles or whichever element as a result of an improper fitting or use.

ONAREA® guarantees its products for 24 months with the exception of those products liable to wear as indicated in guarantee law. For such it is necessary to keep this document for any possible claim/enquiry in which the product serial number should be indicated. The warranty expires after 24 months. From then on any technical assistance costs shall be borne by the user. Please be aware of these guidelines as claims will not be considered for the following motives.

## 2. DELIVERY CONDITIONS AND ELEMENTS

ONAREA® shower trays are delivered in highly resistant individual packaging to avoid claims with deliveries, each tray is supplied with the following items:

- Graphic fitting instructions
- Warranty certificate
- ONAREA® design waste
- Waste trap
- Pipe adaptors
- Performance declaration
- The trays have a dimensional tolerance of +/- 2'00mm

## 3. CONDITIONS FOR USE

For daily cleaning we recommend rinsing the shower tray with water after use, and allowing adequate ventilation in the bathroom. For thorough cleaning, rinse with detergent and water or any readily available bathroom cleaner, washing with a fine non-abrasive sponge. It is important not to use any alcohol based cleaner or detergent. Abrasive items (sponges, cloths or similar) are not suitable for cleaning the tray.

## 4. PRODUCT CHARACTERISTICS

ONAREA® is renowned for evolution, design and innovation, the different ranges show a before and after in the world of shower trays, we are talking about resistant, natural materials with high

performance, creating an ambience and unique space, that also provide a safeguard due to the non-slip system, tested and certified by accredited laboratories.

## • SINGULAR RANGE

The SINGULAR trays are manufactured from a natural stone concept, resistant and beautiful materials applying all the non-slip characteristics found in conventional shower trays, these trays have a high mechanical and impact resistance due to their nature, NATURAL STONE.

## • FINE RANGE

The FINE range is manufactured starting with a mineral resin base where we add our pieces of flexible natural stone Flextone®, creating an ambience in our product range. One of its greatest features is the minimal absorption provided by the combination of mineral resin and fibreglass.

## • ARQUITECT RANGE

The ARQUITECT range was born from the development of mineral resin trays with colour and textures according to market demands. Being highly resistant materials with a mix of unsaturated polyester, calcium carbonate and a vinyl gel epoxy coat, resulting in a non-slip product that hardly stains. Providing an impact resistance similar to our SINGULAR range.

## 5. COLOUR RANGE

The choice of colours offered for each range can be found throughout our general catalogue, in our SINGULAR range the combination of finish, size, colour, all that our customer requires, as these trays are made expressively to our customers request, with the FINE range we adapt our products to the colours of the flexible natural stone Flextone®, the ARQUITECT range providing a wide choice of possible colours with each texture.

## 6. TRAPS AND WASTES

Depending on the tray's finish we offer the option of a square or rectangular waste in each case, the trays are supplied with the corresponding trap.

Traps are manufactured in ABS plastic and the stainless steel waste AISI 304 with both sides polished, with a thickness of 1.5 to 2 mm.

## 1. CONDICIONES GENERALES Y GARANTÍAS

ONAREA® garantiza sus productos y componentes contra cualquier falta de conformidad siempre y cuando se realice un uso adecuado de los mismos y con una correcta instalación. La empresa no se hace responsable de los problemas derivados de una colocación incorrecta o de un uso inadecuado del producto. No se hará cargo de los gastos extraordinarios como la sustitución de mamparas, azulejos o cualquier elemento como consecuencia de un mal uso o mala instalación. ONAREA® garantiza durante 24 meses sus productos a excepción de las piezas de desgaste tal y como se indica en la ley de garantías. Para ello es necesario guardar este documento para posibles incidencias/consultas donde se indica el número de serie del producto. La garantía queda extinguida una vez transcurridos los 24 meses. A partir de este momento la asistencia técnica correrá a cargo del usuario. Tengan en consideración estas normas ya que no se cursarán reclamaciones por estos motivos.

## 2. ELEMENTOS Y CONDICIONES DE ENTREGA

Los platos de ducha ONAREA® se entregan con el embalaje individual y de alta resistencia para evitar incidencias en el transporte. Cada plato se envía con los siguientes elementos:

- Instrucciones gráficas de montaje.
- Certificado de Garantía.
- Rejilla de diseño ONAREA®.
- Sifón de evacuación.
- Tubos de adaptación.
- Declaración de prestaciones.
- Las dimensiones tienen una tolerancia de +/- 2mm.

## 3. CONDICIONES DE USO

Para una limpieza diaria se aconseja enjuagar el plato de ducha después del uso con agua y dejar una ventilación suficiente del cuarto de baño. Para la limpieza profunda se debe enjuagar con agua y jabón, o cualquier tipo de producto de limpieza de baños que existe en el mercado, limpiando este con un esponja fina no abrasiva. Es importante no usar productos de limpieza o desinfectantes que contengan alcohol. Los productos abrasivos (esponjas, trapos o similares) tampoco son adecuados para su limpieza.

## 4. CARACTERÍSTICAS DE NUESTRO PRODUCTOS

ONAREA® es sinónimo de evolución, diseño e innovación, las distintas series marcan un antes y después en mundo del plato de ducha. Hablamos de materiales resistentes, naturales y de altas prestaciones

que crean unos ambientes y espacios únicos, a su vez proporcionan una seguridad gracias a su sistema de antideslizamiento probados y certificados por los laboratorios acreditados.

## • SERIE SINGULAR

La serie SINGULAR son platos fabricados desde el concepto piedra natural, material altamente resistente y bello, aplicando todas las características antideslizantes de los platos de ducha convencionales. Estos platos tienen una resistencia mecánica y al impacto conforme a su naturaleza, PIEDRA NATURAL.

## •SERIE FINE

La serie FINE está fabricada partir de una base de resina mineral a la cual unimos nuestras piezas de piedra natural flexible Flextone®, creando un ambiente en la línea de nuestros productos. Una de sus mayores características es a la absorción mínima que proporciona la unión de la resina mineral y la fibra de vidrio.

## •SERIE ARQUITECT

La serie ARQUITECT nace del desarrollo de los platos de resina mineral con unas texturas y colores acordes a la necesidad del mercado. Son materiales altamente resistentes con una mezcla de poliéster insaturada, carbonato cálcico y gel coat epoxy vinilester, siendo un producto antideslizante y que apenas se ensucia. Tienen una resistencia similar al impacto a nuestra serie SINGULAR.

## 5. GAMA DE COLORES

La gama de colores que presentamos para cada serie la podemos encontrar a lo largo de nuestra catálogo general. En la SERIE SINGULAR hay varias combinaciones en acabado, medida y color, ya que éstos platos están realizados expresamente a petición de las necesidades de nuestros clientes. En la serie FINE adaptamos nuestros productos a los colores de la piedra natural flexible Flextone®, siendo la serie ARQUITECT la que proporciona en cada textura una amplia posibilidad de colores.

## 6. SIFONES Y REJILLAS

Dependiendo del acabado del plato, se ofrecen las variantes de la rejilla cuadrada o rectangular, en cada uno de los casos los platos llevarán el tipo de SIFON que requiera. Los SIFONES se fabrican en plástico ABS mientras que las rejillas son de acero inoxidable AISI 304 con ambas caras pulidas, y tienen un espesor de 1'5 a 2 mm.

## SIFÓN MIAMI

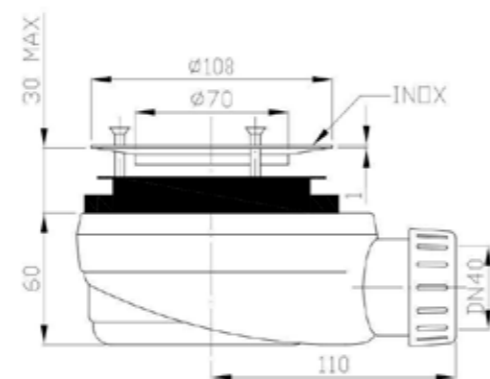

## SIFÓN TAY

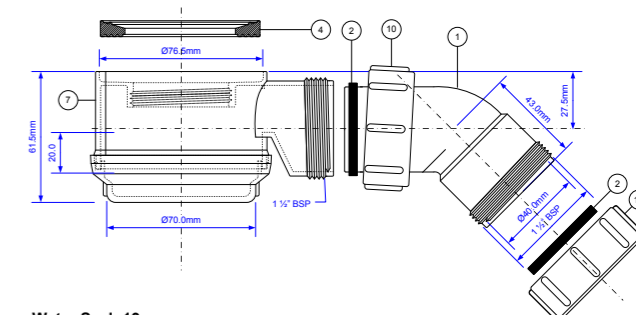

Water Seal: 19mm

## 7. CUTTING OF THE SINGULAR AND FINE RANGES

All Onarea® trays can be factory supplied to a specific size, the FINE range can be sent in a standard size and could be cut by the customer if required, this requires a diamond-tipped disc or saw specifically for cutting natural stone. With the SINGULAR range special sizes must be factory made due to the nature of the product and cannot be cut on site.

The shower trays can only be cut straight with curved cutting not possible.

The FINE range shall incur an additional cost for each cut made at our factory. Please consult our PRICE LIST.

It is important when ordering special sizes that specific information is correctly indicated:

- Length and width sizes in mm
- When cutting is required indicate if the cut is required on the left or right side, it is very important that the sizes are exactly as required.
- We recommend that the cut side is the side fitted against the wall.

## 7. CORTE DE LOS PLATOS SERIE SINGULAR Y FINE

Todos los platos de Onarea® pueden suministrarse desde fábrica a una medida específica. La serie FINE se puede enviar a un formato estándar y ser cortados por el cliente si lo desea. Para ello se deberá usar discos de diamante o herramientas de sierra específicas de corte de piedra. En la serie SINGULAR las medidas especiales deberán ser realizadas desde fábrica dado la naturaleza del producto, no pudiendo realizar cortes en obra.

Los platos solo podrán ser cortados en cortes rectos, no pudiendo realizar cortes curvos.

En la serie FINE los cortes de los platos realizados en fábrica tendrán un incremento por corte realizado, CONSULTAR TARIFA DE PRECIOS. Es importante a la hora realizar los pedidos con medidas especiales indicar correctamente una serie de datos específicos:

- Medidas de ancho y largo en mm.
- En caso de cortes indicar si es en el lado izquierdo o derecho. Es muy importante que para los cortes las medidas sean exactos a la necesidad.
- Es aconsejable realizar los cortes en los lados plato que su colocación esté pegada a la pared.

1. Square cut
2. Angle cut
3. Special cut
4. Mixed cut

1. Corte en escuadra
2. Corte en ángulo
3. Escote
4. Combinada

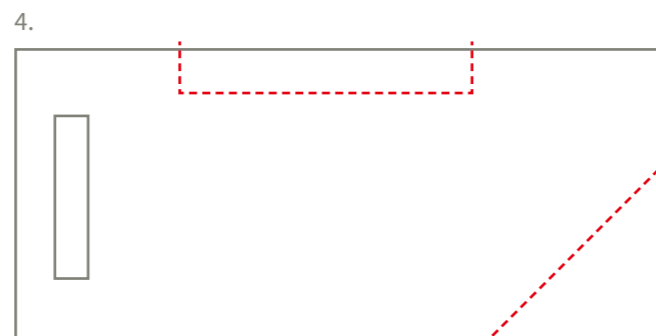
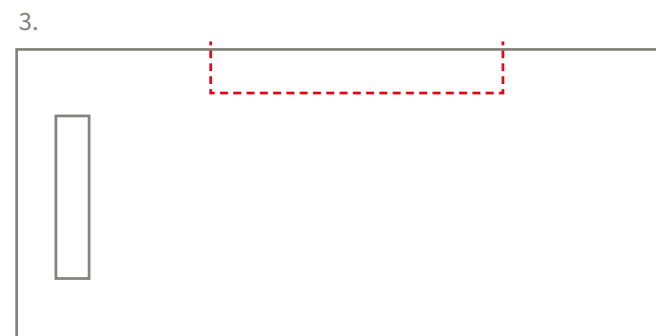
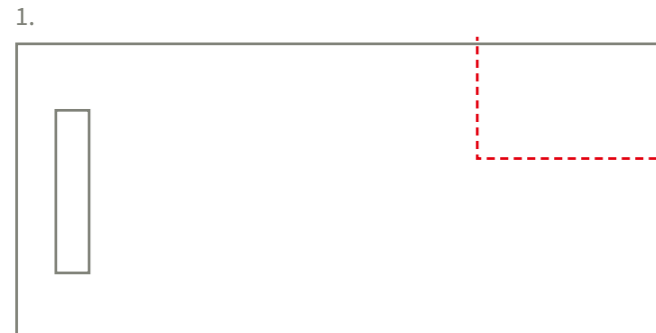

## 8. TESTING UNDERTAKEN

## 8. PRUEBAS Y ENSAYOS REALIZADOS

Aptitud para la limpieza. Cleaning suitability.	UNE-EN 14527:2006 + A1 Apdo. 5-32	Aspecto Superficie. Superficial aspect.
		Evacuación de aguas. Water evacuation.
Durabilidad. Durability .	UNE-EN 14527:2006 + A1 Apdo. 5.2	Estabilidad fondo del plato de ducha. Shower tray base stability.
		Resistencia a los agentes químicos y las manchas. Chemical agents and staining resistance.
		Resistencia a las variaciones de temperatura. Temperature change resistance.
Absorción de agua. Water absorption.	UNE-EN 13755	
Resistencia a la adherencia. Adhesive resistance.	UNE-EN 1015-12	
Resistencia al choque. Impact resistance.	UNE-EN 14158	
Dureza superficial al rayado. Superficial hardness to scratching.	UNE-EN 67101	
Resistencia al deslizamiento. Slip resistance.	UNE-EN 14231	

Agente Domestico. Domestic agent.	Declaración. Declaration.	
Lejías. Bleaches.	24 h	(5)
Salfuman. Hydrochloric acid.	4 h	(1)
Don Limpio. "Mr. Proper".	24 h	(3)
Viakal. "Viakal".	24 h	(4+)
Vinagre. Vinegar.	24 h	(2)
Amoniaco. Ammoniates.	24 h	(4)
Cilit Bang. "Cillit Bang".	24 h	(5)
Acetona. Acetone.	1 min	(1)
Isopropanol. Propanol.	5 min	(5)
Tinte de pelo oscuro. Dark hair dye.	5 min	(2)
Tinte pelo medio. Medium hair dye.	5 min	(2)
Laca de uñas oscuro. Dark nail polish.	5 min	(3)
Laca de uñas clara. Light nail polish.	1 h	(5)
Agua oxigenada. Hydrogen peroxide.	24 h	(3)
Agua oxigenada. Hydrogen peroxide.	1 min	(3)

## 9. SHOWER TRAY COMPONENTS

- A. Shower tray.
- B. stainless steel waste.
- C. Trap.

This instruction manual contains basic instructions for the fitting of the product and the guidelines that must followed for correct fitting of the finished product.

## 10. BASIC GUIDELINES FOR FITTING

- A.** The packaging is used to protect the most fragile parts from possible defects or damage from poor delivery by means of, polystyrene foam, cardboard and transparent film.
- B.** Onarea® shall not be held responsible for any damages during temporary storage outside its premises.
- C.** The fitting shall be solely undertaken by an authorised technician specialising in sanitary ware.
- D.** During fitting the surface, finishes, wall and floor tiles must be protected from the base of the tray.

**E.** All dirt and waste must be avoided, specially everything originates from a blocked waste. The floor where the tray is fitted must be clean, free from water and dry.

**F.** In order to ensure correct fitting, the work must be undertaken in compliance with correct working procedure.

**G.** It is essential that this manual will be read by the personal responsible for the work BEFORE start fitting the SHOWER TRAY. This manual must always be available where the product is to be found.

**H.** Before fitting/using this product ensure that it is complete, free from damage, if any damage is found:

- Meticulously note any damage on the delivery note should it be necessary to claim against the transport company for damaged goods.
- Never use or fit the product if the product is damaged.
- Contact your supplier or retailer.
- Visually check the fragile components of the product prior to removing the packaging.
- Once the above points have been verified, you could proceed with the fitting. The fitting must be undertaken by a specialist always following the instructions below.

## 9. ELEMENTOS QUE CONFORMAN UN PLATO DE DUCHA

- A. Plato de ducha.
- B. Rejilla de acero inox.
- C. Desagüe.

Este manual contiene las instrucciones básicas para el montaje del producto y las indicaciones que se han de cumplir para hacer el montaje correcto del producto final.

## 10. NORMAS BÁSICAS PARA SU MONTAJE

**A.** El embalaje se realizará para proteger las partes más sensibles a posibles agresiones o defectos derivados de un mal transporte con los medios adecuados, mediante poliespan, cartón, film transparente.

**B.** Onarea® no se responsabiliza de los daños originados por el almacenamiento provisional fuera de sus instalaciones.

**C.** La instalación deberá efectuarse únicamente por un técnico autorizado especialista en sanitarios.

**D.** Durante la instalación se deberá proteger las superficies, los revestimientos, la pared y las baldosas del suelo de los platos de ducha.

**E.** Deberá evitar cualquier tipo de suciedad, en concreto suciedad que

podiera originarse por obstrucción del desagüe. El suelo sobre el que se asienta el plato de ducha deberá estar limpio, sin agua y seco.

**F.** Con el fin de asegurar una buena instalación, las fases de trabajo deberán de realizarse respetando los tiempos de trabajo.

**G.** Es imperativo que este manual sea leído por el personal responsable operador antes de proceder a la instalación y montaje del PLATO DE DUCHA. Este manual debe de estar siempre disponible en el lugar en que, encada momento, se encuentre e producto.

**H.** Antes de utilizar el producto asegúrese de que está íntegro y no dañado. Si se aprecian daños:

- Enumere meticulosamente los daños en el albarán de entrega por si fuese preciso reclamar al transportista por daños en la mercancía.
- No utilizar ni instalar el producto en el caso de irregularidades en el producto.
- Diríjase al vendedor o proveedor.
- Para los elementos sensibles o partes del producto antes de proceder a quitar el embalaje se recomienda un control visual del mismo.
- Una vez verificados los puntos anteriores se puede proceder a la instalación del PLATO DE DUCHA. Dicha operación se realizará por personal cualificado y siempre siguiendo el siguiente orden.

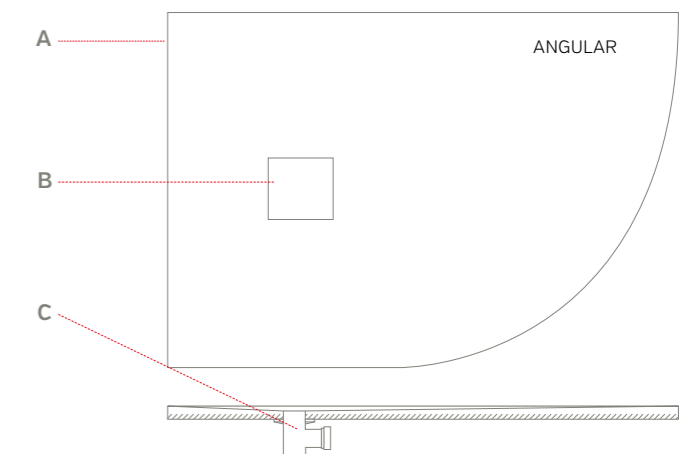
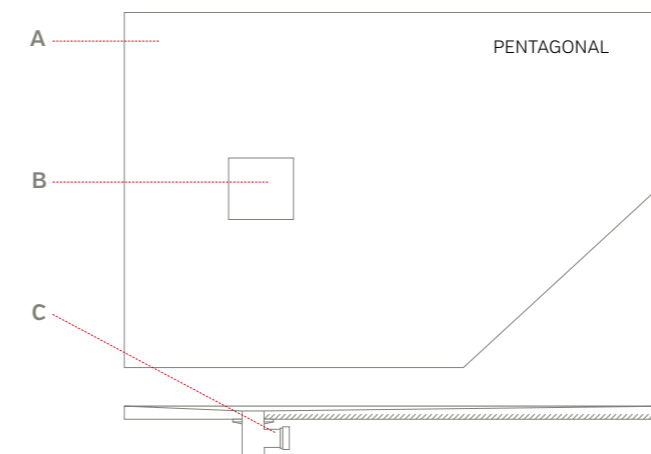
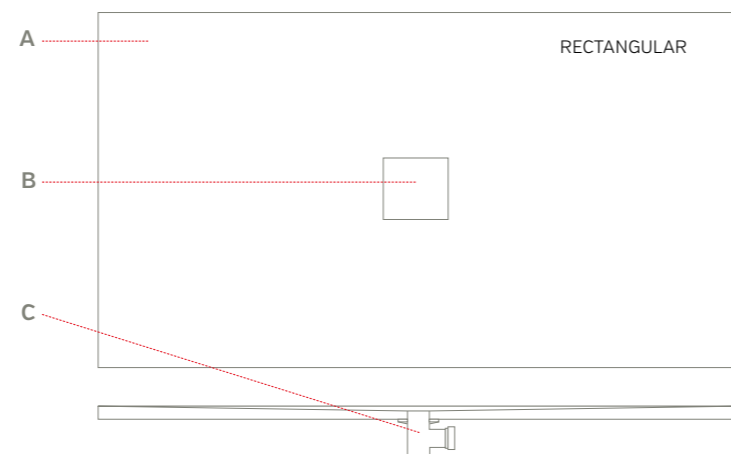
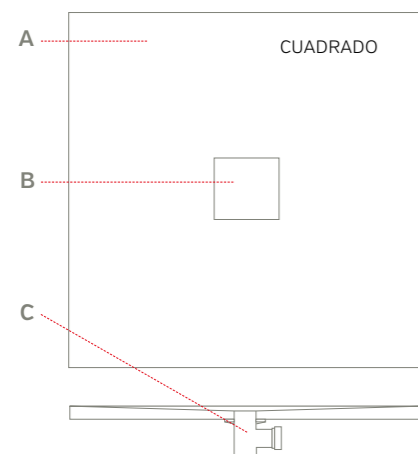

### 11. FLUSH FITTING THE SHOWER TRAY

With this type of fitting, the highest part of the tray is flush with the surrounding floor tiles with the benefit of no step when entering the shower space. This option is beneficial to persons with limited or reduced mobility, especially those who require a wheelchair.

In this case it is important to take into consideration these 2 fundamental points:

- Measurements for sinking the tray:

Firstly, there needs to be enough space on site for the tray to be sunk into the floor. This depth should be the minimum required to sink the tray plus the space necessary for the plumbing. This measurement can vary depending on the range of shower tray. However, generally speaking, the mineral resin trays which are more widely used for this type of fitting are usually between 3-4cm, the thickness of the tray, plus a further 9cm-10cm necessary for the plumbing. Therefore, we normally require a depth of between 12-14 cm. Shorter profile plumbing is also available for shower trays, which can reduce the required depth for the plumbing from 10cm to 6-7cm resulting in a total required depth of 10 cm.

- Finishing off the joint between the shower tray and the surrounding flooring:

The other important point to take in mind is how to resolve the joint between the tray and the rest of the floor. It is essential that this joint is completely sealed in order to avoid possible leaks in the future. In some cases, there is a tendency to rely on fitting a shower screen on this joint to resolve this problem but this is not the case, as some shower screens do not have lower tracks and even if they do, this still does not cover the area. As such, it is important that the fitter addresses this point.

### 12. SURFACE-FITTED SHOWER TRAY

This type of fitting is basically the same as the previous one, but with the difference that the edges of the shower tray remain 3-4 cm above the floor

level. As before, space is needed to sink the plumbing, but only about 9-10 cm, as the thickness of the shower tray remains above the floor. The joint between the shower tray and the floor is not as problematic as the previous one because the shower tray sits on the floor instead of butt jointed.

It is also convenient fitting, even for disabled persons as the step up is only 3 cm, which is easily accessible with a wheelchair.

Installing the shower tray in this way doesn't require any vertical finishing off, such as skirting, because the edge of the shower tray serves this function.

This type of fitting is recommended for ease of access and fitting, whenever sufficient space is available.

### 13. RAISED OR SEMI-FLUSH SHOWER TRAYS

This type of fixing is suitable when there is insufficient depth for fully flush fitting in the floor. When this is the case the tray must be raised. The fitted height should be the sum of the tray depth plus space for the plumbing and waste, approximately 12-13cm.

For this type of fitting the base must be solidly bedded beneath the shower tray. Because the resin shower trays are very rigid and resistant, it is mistakenly believed they can be fitted with just dabs, but this would leave voids under the tray which would cause problems, such as distorting the tray, or cracking. Resin trays must always be fitted onto a solid, level base.

The space between the raised shower tray and the floor must be suitably finished. This can be done with the bathroom wall tiles or skirting pieces the same colour as the tray, giving a uniform finish.

This is also the case when the shower tray is semi-flush fitted. When there is insufficient space to sink the plumbing completely below floor level. In this event, the shower tray can be left as low as possible according to the available space. In this way we can see shower trays fitted with heights between 3-13 cm, as previously mentioned.

### 11. INSTALACIÓN ENRASADA O EMPOTRADA DEL PLATO DE DUCHA

En este tipo de instalación la parte más alta queda alineada con el pavimento que rodea el plato de ducha con lo que tenemos la ventaja de que no existe ningún tipo de escalón a la hora de acceder al espacio de ducha. Esta es una opción especialmente ventajosa en caso de personas con minusvalías o movilidad reducida, sobre todo en aquellos casos en que sea necesario el uso de silla de ruedas.

En este caso, es importante tener en cuenta dos cosas fundamentales:

- Medida para profundizar:

Por una parte, que dispongamos del espacio suficiente en la obra como para conseguir profundizar bastante. Este espacio deberá ser como mínimo igual a la suma del grosor del plato más el espacio necesario que requiera la válvula. Esta medida varía dependiendo de cada modelo de plato de ducha, pero como término general en los platos de resinas minerales que son los más utilizados para este tipo de colocación, suele ser de entre 3 cm. y 4 cm. de grosor del plato, más otros 9 ó 10 cm. que necesita la válvula. Por tanto, necesitaremos rebajar al suelo un hueco de entre 12 y 14 cm. También existen válvulas de perfil bajo para platos de ducha que podrían reducir de 10 a 6 ó 7 cm. de altura la medida de la válvula lo que supondría una necesidad de unos 10 cm. de profundidad total.

- Remate de unión entre el plato y el pavimento que lo rodea:

La otra cuestión importante a tener en cuenta es cómo resolver la junta entre el plato de ducha y el resto del suelo. Es muy importante que dicha unión quede perfectamente sellada a fin de evitar posibles humedades o filtraciones en un futuro. En algunos casos se tiende a pensar que la colocación de una mampara de ducha sobre esta junta resolverá el problema, pero esto no es cierto ya que en algunos casos hay mamparas que no llevan guía inferior, y aun llevándola no taparán esa zona. Por tanto, es importante que el instalador del plato deje resuelto este punto.

### 12. INSTALACIÓN EN SUPERFICIE DEL PLATO DE DUCHA

Este tipo de instalación de plato de ducha es esencialmente muy parecida a la anterior pero con la diferencia de que en este caso queda fuera del suelo el canto del plato por lo que tendremos el plato de ducha elevado unos 3 ó 4 cm. por encima del nivel del suelo.

Como en el caso anterior, necesitaremos espacio para profundizar, aunque en este caso sólo necesitaremos de hueco la medida que nos haga la válvula, es decir unos 9 ó 10 cm. ya que el grosor del canto del plato de ducha queda por encima de la superficie.

En este tipo de instalación de plato de ducha, la junta entre el plato y el suelo no es tan delicada ya que el plato de ducha queda solapado sobre el

suelo de manera que evitamos la unión a testa que teníamos en la anterior instalación.

Es una instalación también muy cómoda incluso para personas con minusvalías ya que el escalón de acceso a la ducha es de tan sólo 3 cm. que se pueden salvar fácilmente con una silla de ruedas.

Si instalamos el plato de ducha de esta manera no requeriremos de ningún remate vertical tipo zócalo ya que es el canto del plato el que hará esta función.

Este tipo de instalación es muy recomendable por la comodidad de acceso y la facilidad de instalación, siempre que dispongamos del espacio de profundidad necesario para llevarlo a cabo.

### 13. INSTALACIÓN ELEVADA O SEMI-ELEVADA DEL PLATO DE DUCHA

Esta es la instalación habitual cuando no se dispone de espacio para poder profundizar en el suelo. Al no contar con esta posibilidad, la instalación del plato tiene que ser elevada. La altura del plato será la suma del grosor del plato de ducha más la altura requerida por el desagüe, es decir, de unos 12 - 13 cm. en total aproximadamente.

Para este tipo de instalación es muy importante tener en cuenta que deberemos macizar completamente la base de obra por debajo del plato de ducha. Debido a que los platos de resinas minerales son extremadamente rígidos y resistentes se puede llegar a pensar que simplemente dejándolos con algunos puntos de apoyo y dejando la base hueca es posible instalarlos. Esta es una creencia completamente equivocada, ya que esto nos podría generar problemas en el futuro que pueden llegar a hacer que el plato se deforme o agriete. Los platos de resinas siempre deben apoyar sobre una base maciza de obra y totalmente plana para dejarlos correctamente instalados.

La medida de altura a la que hayamos elevado el plato la deberemos revestir frontalmente. Esto lo podemos hacer con el azulejo del baño o bien con los zócalos que se venden del mismo material y color del plato creando una superficie completamente uniforme.

También se da muy frecuentemente el caso de lo que hemos llamado instalación de plato de ducha semi-elevada. En este caso, disponemos de margen para profundizar en la zona del desagüe pero no de suficiente medida como para lograr dejarlo completamente oculto debajo del nivel del suelo. En estos casos, podremos dejar el plato lo más bajo posible dentro de las posibilidades de medida que nos dé el espacio de que disponemos. De esta forma, podremos encontrar casos con platos de ducha instalados con alturas entre los 3 cm. y los 13 cm. comentados en las anteriores instalaciones.

### 11.

#### FLUSH FITTING THE SHOWER TRAY

#### INSTALACIÓN ENRASADA O EMPOTRADA DEL PLATO DE DUCHA

### 12.

#### INSTALACIÓN EN SUPERFICIE DEL PLATO DE DUCHA

#### SURFACE-FITTED SHOWER TRAY

### 13.

#### INSTALACIÓN ELEVADA O SEMI-ELEVADA DEL PLATO DE DUCHA

#### RAISED OR SEMI-FLUSH SHOWER TRAYS

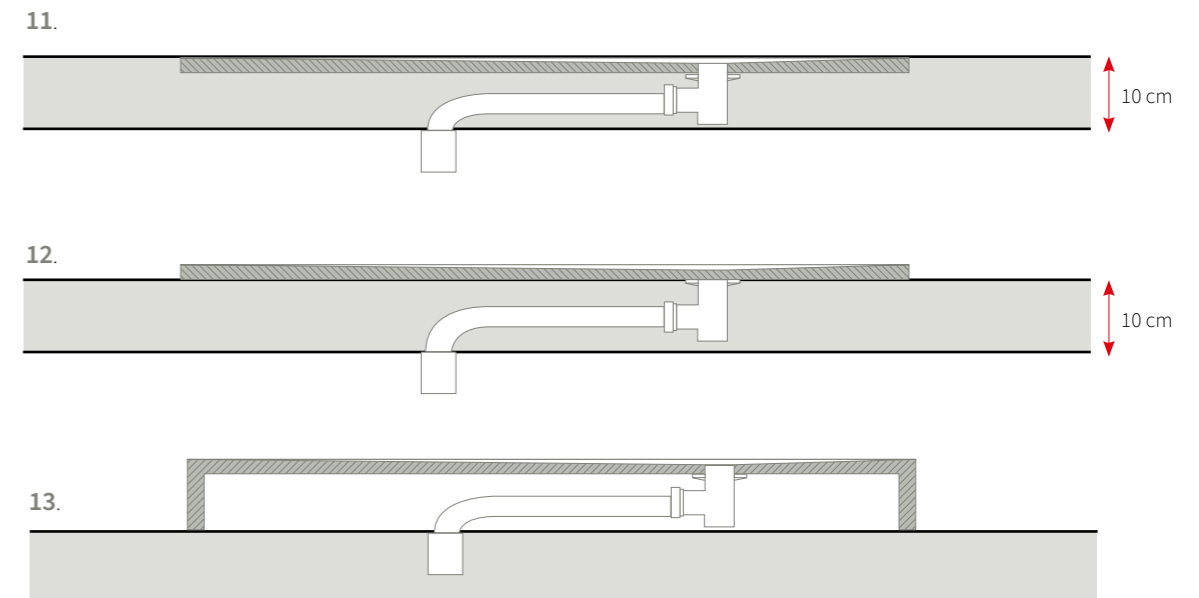

#### 14. FITTING THE SHOWER TRAY

1. Before applying the adhesive to the base, ensure that the trays sit correctly and there is no unevenness. If necessary, test the waste with water.
2. Apply the adhesive (we recommend polyurethane mastic or similar) uniformly over the surface.
3. Fit the tray and allow the product to cure according to the manufacturer's instructions.

4. Check the tray is level then finish fitting the waste.
5. Apply masking tape around the edge of the tray, never to the floor or wall. Apply a joint sealing compound, we recommend a highly flexible silicone, around the edges. Remove the tape and allow the silicone to cure according to the manufacturer's instructions. Fit the stainless steel waste cover.
6. Clean the tray and walls with a non-abrasive cloth.

Note:  
Under no circumstances should the product be modified. In the event of any modification, ONAREA® WILL NOT BE RESPONSIBLE FOR ITS PERFORMANCE.

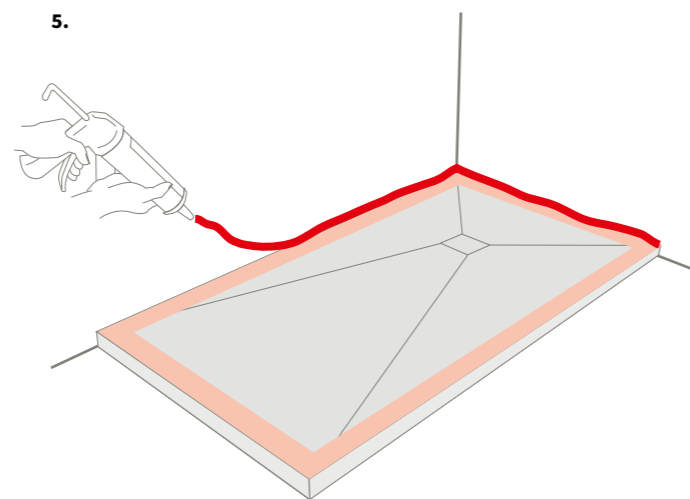
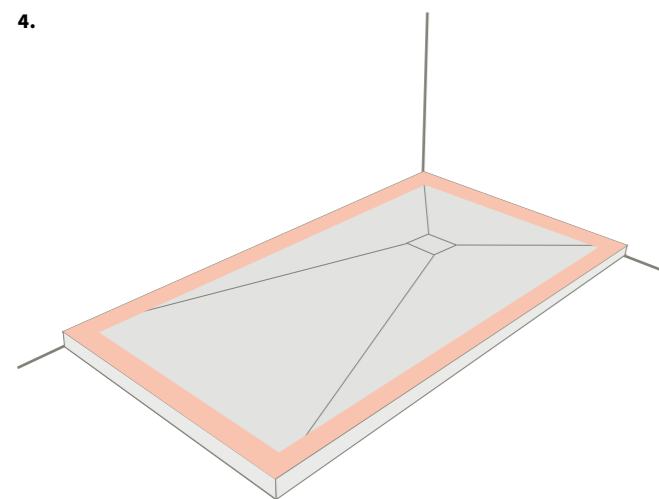
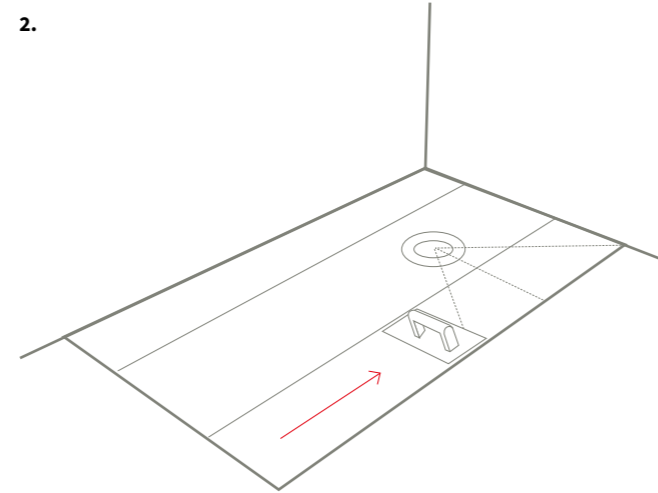
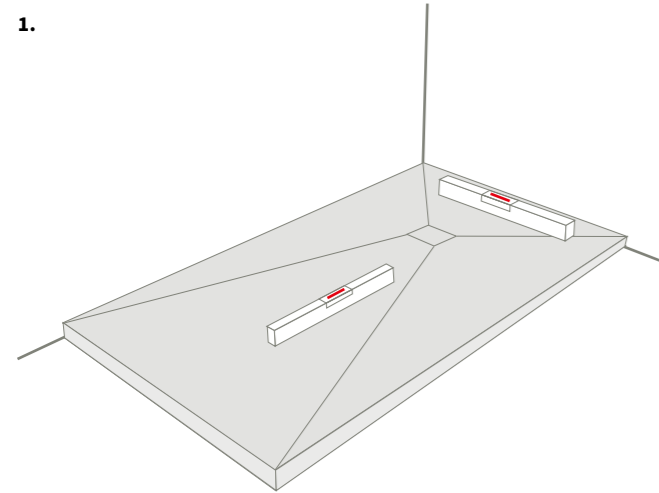

#### 14. INSTALACIÓN DE PLATOS

1. Antes de poner el adhesivo sobre la base, comprobar que el plato asiente bien y no tenga problemas de desnivel. Si es preciso, comprobar con agua que desagüe.
2. Aplicar el adhesivo (se recomienda masilla de poliuretano o similar), distribuyendo de forma uniforme.
3. Comprobar el nivelado del plato de ducha y terminar el montaje del desagüe.

4. Colocar cinta de carroceros sobre el plato, nunca sobre pared y suelo.
5. Aplicar un sellante de juntas (se recomienda silicona elástica de alta capacidad de deformación) por todo el perímetro, retirar la cinta y dejar actuar según especificaciones del fabricante. Colocar la rejilla de acero inoxidable.
6. Limpiar el plato con un paño no abrasivo y el revestimiento de la pared.

Nota:  
El producto no debe de ser, por ningún motivo modificado, en caso contrario ONAREA® NO SE HACE RESPONSABLE DE SU FUNCIONAMIENTO.

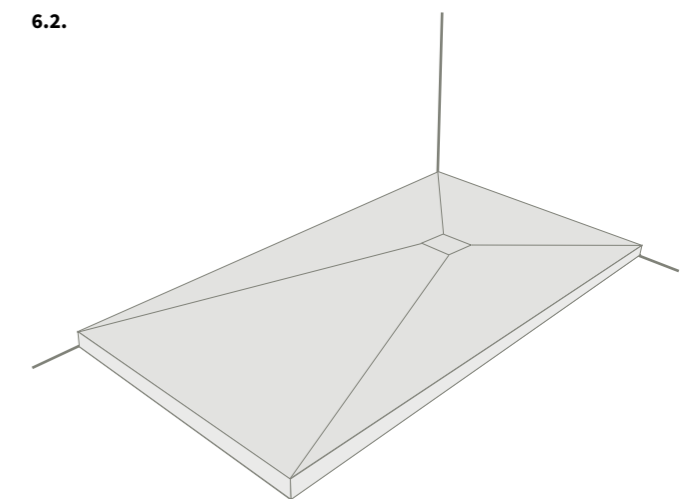
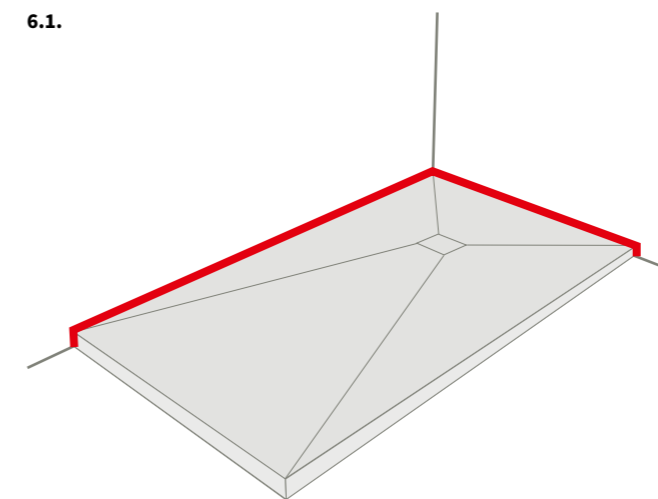
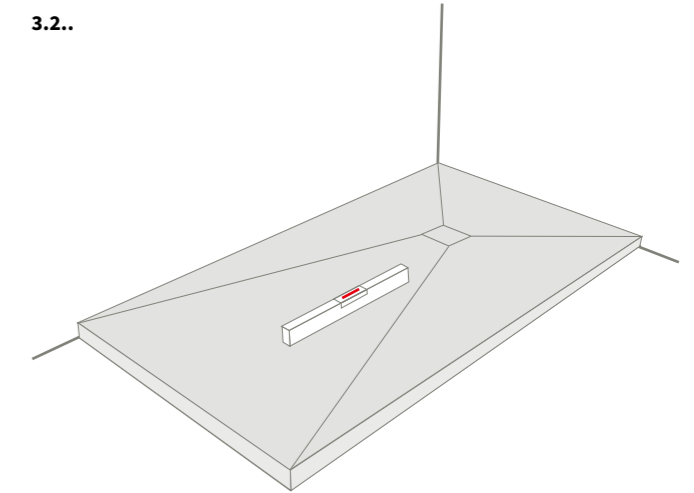
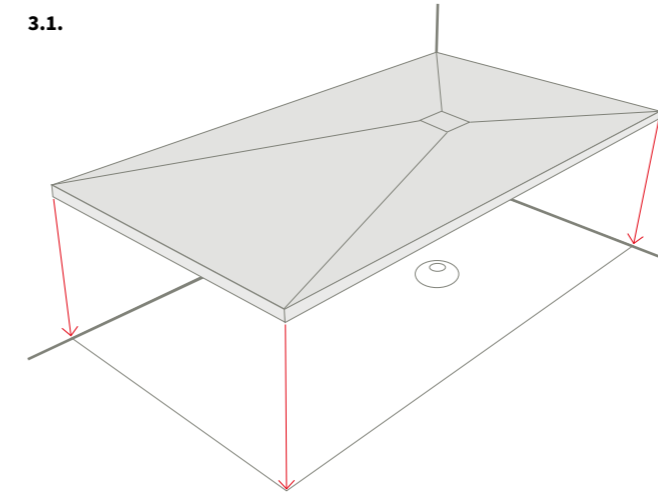



PACKING

Width	Long	FINE	
		RIN	SINGULAR
		ARQUITECT	
Width	Long	Kg /u.	Kg /u.
70	80	26,50 Kg	44,80 Kg
70	90	30,00 Kg	50,40 Kg
70	100	33,00 Kg	56,00 Kg
70	110	36,50 Kg	61,60 Kg
70	120	40,00 Kg	67,20 Kg
70	130	43,00 Kg	72,80 Kg
70	140	46,50 Kg	78,40 Kg
70	150	49,50 Kg	84,00 Kg
70	160	53,00 Kg	89,60 Kg
70	170	56,50 Kg	95,20 Kg
70	180	60,00 Kg	100,80 Kg
70	190	63,00 Kg	106,40 Kg
70	200	66,50 Kg	112,00 Kg
90	80	34,00 Kg	57,60 Kg
90	90	38,50 Kg	64,80 Kg
90	100	42,50 Kg	72,00 Kg
90	110	47,00 Kg	79,20 Kg
90	120	51,00 Kg	86,40 Kg
90	130	55,50 Kg	93,60 Kg
90	140	60,00 Kg	100,80 Kg
90	150	64,00 Kg	108,00 Kg
90	160	68,00 Kg	115,20 Kg
90	170	72,50 Kg	122,40 Kg
90	180	77,00 Kg	129,60 Kg
90	190	81,00 Kg	136,80 Kg
90	200	85,00 Kg	144,00 Kg

Width	Long	FINE	
		RIN	SINGULAR
		ARQUITECT	
Width	Long	Kg /u.	Kg /u.
80	80	30,50 Kg	51,20 Kg
80	90	34,00 Kg	57,60 Kg
80	100	38,00 Kg	64,00 Kg
80	110	42,00 Kg	70,40 Kg
80	120	45,50 Kg	76,80 Kg
80	130	49,50 Kg	83,20 Kg
80	140	53,00 Kg	89,60 Kg
80	150	57,00 Kg	96,00 Kg
80	160	60,50 Kg	102,40 Kg
80	170	64,50 Kg	108,80 Kg
80	180	68,00 Kg	115,20 Kg
80	190	72,00 Kg	121,60 Kg
80	200	76,00 Kg	128,00 Kg
100	80	38,00 Kg	64,00 Kg
100	90	42,50 Kg	72,00 Kg
100	100	47,50 Kg	80,00 Kg
100	110	52,00 Kg	88,00 Kg
100	120	57,00 Kg	96,00 Kg
100	130	61,50 Kg	104,00 Kg
100	140	66,00 Kg	112,00 Kg
100	150	71,00 Kg	120,00 Kg
100	160	76,00 Kg	128,00 Kg
100	170	80,50 Kg	136,00 Kg
100	180	85,00 Kg	144,00 Kg
100	190	90,00 Kg	152,00 Kg
100	200	95,00 Kg	160,00 Kg

FINISHES ACABADO DISEÑO

Ref.	Definition Definición
BR	Border Bordes
CA	Fall from zero Caída desde Cero
PL	Flat Plano
TR	Triangular striped Triangular Rayado

WASTE FINISH ACABADO REJILLA

Ref.	Definition Definición
CU	Square Cuadrada
RT	Rectangular Rectangular

CERTIFICACIÓN

Singular.

Ctra. Pedro Muñoz, Km. 1 - Nave 58  
Apdo. Correos 51  
13700 Tomelloso (Ciudad Real)  
Tel. 926 501060 /Tel.Fax: 926 506450  
ITP15044-2



CONCLUSIONES. EVALUACIÓN DE REQUISITOS APPLICABLES A PLATOS DE DUCHA

Servicio: ITP15044

Muestra a ensayar: Plato de ducha de uso doméstico.  
Material: Soporte piedra natural  
Dimensiones: 1600 x 700 mm, e: 25mm

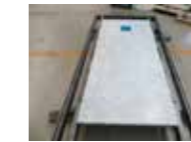

Fecha de recepción: 02/12/2015  
Nº Referencia Itecam: MAT-ITP15044-2  
Fecha de ensayo: 09/12/2015- 19/01/2016  
Cliente: ANIASORA, S.L.

RESULTADOS DE ENSAYO

ENSAYOS REALIZADOS	CONDICIONES DE ENSAYOS SEGÚN NORMA	RESULTADO	CLASE
<b>Aptitud para la limpieza.</b> • Aspecto de la superficie según apartado. • Evacuación de agua según apartado.	UNE-EN 14527:2006+A1:2010. Apdo. 5.2	CORRECTO	1 Según UNE-EN 14527:2006+A1:2010
<b>Durabilidad</b> • Estabilidad del del fondo del plato de ducha. • Resistencia a los agentes químicos y a las manchas • Resistencia a las variaciones de temperatura	UNE-EN 14527:2006+A1:2010. Apdo. 5.3	SIN DETERIORO	
<b>Absorción de agua</b>	UNE-EN 13755:2008	0,1 %	-
<b>Determinación de la Energía de rotura</b>	UNE-EN 14158:2004	1961 J	-
<b>Dureza superficial al rayado</b>	UNE 67101/M1	Dureza de Mohs 6	-
<b>Resistencia al deslizamiento</b>	UNE-ENV 12633:2003	USRV 107	3 según CTE DB-SUA-1

Conforme a los ensayos solicitados por el cliente y el resultado obtenido en los mismos, se puede asignar a la muestra la CLASE 1 según la norma indicada UNE-EN 14527.



Fine.

Ctra. Pedro Muñoz, Km. 1 - Nave 58  
Apdo. Correos 51  
13700 Tomelloso (Ciudad Real)  
Tel. 926 501060 /Tel.Fax: 926 506450  
ITP15044-1



CONCLUSIONES. EVALUACIÓN DE REQUISITOS APPLICABLES A PLATOS DE DUCHA

Servicio: ITP15044

Muestra a ensayar: Plato de ducha de uso doméstico.  
Material: Soporte mineral con placa de piedra natural de 1,2 mm  
Dimensiones: 1600 x 1000 mm, e:25 mm



Fecha de recepción: 18/11/2015  
Nº Referencia Itecam: MAT-ITP15044-1  
Fecha de ensayo: 24/11/2015- 18/01/2016  
Cliente: ANIASORA, S.L.

RESULTADOS DE ENSAYO

ENSAYOS REALIZADOS	CONDICIONES DE ENSAYOS SEGÚN NORMA	RESULTADO	CLASE
<b>Aptitud para la limpieza.</b> • Aspecto de la superficie según apartado. • Evacuación de agua según apartado.	UNE-EN 14527:2006+A1:2010. Apdo. 5.2	CORRECTO	1 Según UNE-EN 14527:2006+A1:2010
<b>Durabilidad</b> • Estabilidad del del fondo del plato de ducha. • Resistencia a los agentes químicos y a las manchas • Resistencia a las variaciones de temperatura	UNE-EN 14527:2006+A1:2010. Apdo. 5.3	SIN DETERIORO	
<b>Absorción de agua</b>	UNE-EN 13755:2008	0,2 %	-
<b>Resistencia a la adherencia</b>	UNE-EN 1015-12:2000	0,05 N/mm <sup>2</sup>	-
<b>Determinación de la Energía de rotura</b>	UNE-EN 14158:2004	4903 J	-
<b>Dureza superficial al rayado</b>	UNE 67101/M1	Dureza de Mohs 5	-
<b>Resistencia al deslizamiento</b>	UNE-ENV 12633:2003	USRV 114	3 según CTE DB-SUA-1

Conforme a los ensayos solicitados por el cliente y el resultado obtenido en los mismos, se puede asignar a la muestra la CLASE 1 según la norma indicada UNE-EN 14527.

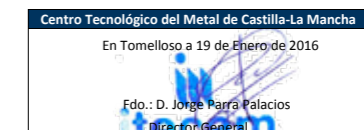

# ESPECIFICACIONES

## FIXING OF TILES

### 1. PREPARATION OF THE SUPPORT SURFACE BEFORE LAYING THE TILES.

For the correct laying of the tiles, we will make a diagnosis of the support or surface taking into account: the stability, the compactness of the intermediate layers, cohesion, and capacity of water absorption, texture, chemical compatibility and the state of the support surface that will receive the tile adhesive.

The surface to cover must be flat, dry, and free of grease/oil and dust and have the suitable stability.

It is very important to respect the setting times of the material used in the supports so as to avoid possible tensions and structural movements that could be transmitted to the superior layers.

### 2. FIXING OF TILES.

The laying of the porcelain tile should be made by means of the “fine layer” technique using adhesive cements or resin bases bi-component adhesives. It is not advisable to use traditional mortar; due to the low water absorption of the tile it does not guarantee the adhesion.

#### 2.1. GENERAL REQUIREMENTS

Generally, C2 type cement adhesives should be used, especially in exteriors and on no conventional supports. The maximum thickness of the layer of adhesive cement is to be between 5 and 10 mm.

The adhesive is to be applied with an indented trowel to assure the homogeneity the layer.

It is not recommended to dampen the tile with water before laying. The adhesive should be protected from drying out quickly.

#### 2.2. ENVIRONMENTAL CONDITIONS.

The tiles should be laid when the surrounding temperature, the temperature of the support and the materials are between 5 °C and 30 °C.

Wind/Speed not superior to 50 km/h. Avoid rain when laying tiles outdoors.

#### 2.3. PREPARATION OF THE ADHESIVES.

Adhesive cement:

Is to be prepared according to the indications of the manufacturer, with the suitable tools and clean water. It is to be mixed with a mixer at low revolutions until obtaining a homogenous, lump free paste.

It will be used within the period stated by the manufacturer, and is not to be re-mixed with additional water. The amount of adhesive to be mixed should be calculated and adjusted to the environmental conditions and the speed in which the tiles are laid.

Adhesives in dispersion:

Usually they are commercialized in a paste form and are ready for use.

Reaction resin adhesive:

These are to be prepared following the indications of the manufacturer.

It is of vital importance to use the components in the stated proportions.

It is also recommended the use of a mixer when preparing the adhesive and that the adhesive is prepared within the recommended temperature. (Usually between 10 and 25 °C).

#### 2.4. APPLICATION OF ADHESIVE.

The selection of the trowel depends on factors such as type of installation, flatness of the surface, dimensions of the floor tile and type of adhesive that is going to be used. An adequate amount of adhesive is to be extended with an indented trowel on the positioning surface.

It is important that the adhesive is used within the stated time once mixed or open to environmental conditions, after a period of time a dry film will form on the surface of the adhesive and this will harm the adhesion of the tile. The tile is to be laid on the layer of adhesive by means of a sliding movement and applying pressure downwards.

#### 2.5. DOUBLE APPLICATION OF ADHESIVE.

The double application of adhesive should be used when fixing wall of floor tiles in exteriors, the fixing of floor tiles superior in size

of 35 x 35cm or in the fixing of floor tiles for interior use that may be submitted to large dynamic and static loads.

Application: the adhesive is to be applied to the supporting structure with an indented trowel. The adhesive is also applied to the rear side

of the tile with a smooth side trowel.

The final thickness of the adhesive should not exceed the maximum recommended thickness stated by the manufacturer. The tiles must

be fixed before the dry film is formed on the surface of the adhesive.

#### 2.6. FIXING OF THE FLOOR TILES.

Before commencing with the fixing of the tiles it is highly recommended to open and mix the tiles from several boxes. It is also recommended that a number of tiles be placed on the support surface to verify the finish to be obtained.

The tiles must be fixed with straight and regular spaces between each tile; the width of the space between each tile depends upon the size/format of the tiles to be fixed. It is not advisable to leave a gap of less than 1.5mm between each tile. In no case should the tiles be fixed without leaving a space.

The excess adhesive is to be removed from the tile before setting.

When fixing rectangular tiles in the “brick bond” effect, the tiles should be staggered no more than 1/3 of the length of the tile.

Once installed and while setting the tile must be protected from adverse weather conditions such as frost, it should also be protected from setting too quickly.

Care should also be taken in the manipulation of the tiles to prevent scratches and chipped edges, the material is served with a wax protection, and this protection can be removed with just hot water

at the conclusion of the work.

#### 3.1. STRUCTURAL JOINTS.

These must be respected in length and width; they must also each of the different layers involved. In the case that they have been done manually, the fillers must have a flexibility of at least 15%.

#### 3.2. PERIMETER JOINT.

These must be as deep as the “base support” or at least as deep as the first solid support and must have a width of 6mm.

#### 3.3. INTERMEDIATE JOINTS.

In interiors, the total surface should be divided with intermediate joints every 40m2 and in exteriors every 25m2. These should penetrate in depth the same as intermediate joints and the width is established with the maximum expected movement.

#### 4. GROUT.

The tile is to be grouted 24 hours after the tile has been installed/completed. The grout shall be applied as instructed by the manufacturer; a material of type CG2 is generally used.

In special cases, such as high chemical resistance is required, a material of type RG2 is used. For the correct application of the grout it is recommended the use of a grout float.

#### 5. CLEANING.

For the correct installation of the tile it is necessary to proceed with the correct cleaning, at the end of the fixing of the tile.

It is important to remove the remainders of the cements, adhesives and grouts with the adequate removing agent. It is important to use a slight acid based detergent diluted with water and maintain in contact with the tile as briefly as possible. NEVER USE CLEANING AGENTS OR DERIVATIVES THAT CONTAIN HYDROCHLORIC OR HYDROFLUORIC ACID.

We advise that before cleaning with any type of chemical based cleaner you should impregnate the whole area with plenty of water to avoid the possible absorption via the grouting materials.

It is not advised the use of chemical based cleaners on areas that have been recently installed as they may create a reaction between the grouted areas and/or the adhesives.

THE COMPANY WILL NOT BE HELD RESPONSIBLE FOR INSTALLED MATERIALS.

WE DO NOT HOLD RESPONSIBILITY FOR THE USE OF FLOOR TILES IN PLACES DIFFERENT TO THOSE RECOMMENDED OR FOR THE INCORRECT

USE OF RAPID SETTING ADHESIVES.

## COMBINED STONE AND GLASS

### 1. TECHNICAL SPECIFICATIONS AND USE.

Low resistance to chemical attack.

Dimensional tolerance of the ceramic base: +0.6%

Good resistance to attack by microorganisms.

Best used for indoor cladding.

Shades of colour vary.

Do not store in damp areas.

### 2. SURFACE PREPARATION.

The wall to be clad must be perfectly clean, dry and flat.

### 3. FIXING MATERIAL.

Use C2 thin set or epoxy adhesives for perfect adherence.

Read manufacturer’s instructions carefully.

### 4. PLACEMENT.

Spread a thin layer of adhesive on the surface and place the stone before the adhesive starts to harden.

Use a damp sponge to remove excess adhesive before it hardens.

### 5. POINTING AND CUTTING.

Make sure the adhesive is completely dry before pointing.

Read the paste manufacturer’s instructions before pointing.

Use a damp sponge and water to remove excess paste.

### 6. CLEANING AND UPKEEP.

Use a sponge and water or neutral detergents.

Do not use abrasive and anti-calc products.

## PRECIOUS STONES

### 1. TECHNICAL SPECIFICATIONS AND USE.

Low resistance to chemical attack.

Used only for cladding.

100% natural.

Broad range of shades, colours and sizes.

### 2. SURFACE PREPARATION.

The wall to be clad must be perfectly clean, dry and flat.

We recommend painting the wall white to make the adhesive as invisible as possible.

Waterproof the wall before cladding in wet areas.

### 3. FIXING MATERIAL.

We recommend using H40 material, since it can serve as a combined fixing thin set and pointing paste.

### 4. PLACEMENT.

The material must be perfectly clean and dry on both sides, where it comes into contact with the adhesive and on the front face.

Place the parts close together, touching, without leaving space for the pointing.

Spread the adhesive along the edges and in the middle of the piece.

Place the piece and then slide it a bit on the wall to fill in the hollows.

If you find a hollow between the meshes after placement, cover them with loose pieces for a good finish.

### 5. POINTING AND CUTTING.











Use standard pointing paste if you prefer pointing the finish.

### 6. CLEANING AND UPKEEP.

Use a sponge and water or neutral detergents.

Do not use abrasive and anti-calc products.

## SYMBOLS

 Wall tiles	 Anti-slip
 Floor tiles	 Illuminated from behind
 Flexible material	 Porcelain tile
 Inkjet	 Rectified
 White body	 Rectified and brush-hammered
 White slide variation	 Rectified and semi-polished

[www.anjasora.com/caracteristicas-tecnicas](http://www.anjasora.com/caracteristicas-tecnicas)

# CARACTERÍSTICAS TÉCNICAS

## COLOCACIÓN

### 1. SOPORTES DE COLOCACIÓN.

Para la correcta colocación, realizaremos un diagnóstico del soporte o superficie teniendo en cuenta: la estabilidad, la compresibilidad de las capas intermedias, la plenitud, cohesión, capacidad de absorción de agua, textura, compatibilidad química y estado de la superficie de colocación que recibirá el material de agarre.

La superficie a recubrir debe estar plana, seca, y libre de grasa aceite o polvo y poseer la estabilidad adecuada.

Es muy importante, respetar los tiempos adecuados de fraguado y maduración de los soportes para que puedan soportar correctamente las cargas y evitar posibles tensiones y movimientos estructurales que podrían transmitirse a las capassuperiores.

### 2. COLOCACIÓN.

La colocación de gres porcelánico se realizará mediante la técnica de capa fina utilizando adhesivos cementosos o bien adhesivos de resinas de reacción. Se desaconseja la utilización de la técnica de capa gruesa con morteros tradicionales ya que la muy baja capacidad de absorción de agua del porcelánico no garantiza la adherencia.

#### 2.1. REQUISITOS GENERALES.

Generalmente se utilizará adhesivos cementosos tipo C2, especialmente en exteriores y sobre soportes no convencionales. Capa del material de agarre entre 5 y 10 mm máximo de espesor.

Se precisa aplicar con llana dentada para asegurar la homogeneidad de la capa. Soportes con planitud tipo I (desviación < 3 mm medidos en regla de 2 m). El adhesivo debe ser protegido de un secado rápido. No es recomendable humectar la baldosa con agua.

#### 2.2. CONDICIONES AMBIENTALES.

La aplicación se debe realizar cuando la temperatura ambiente, la temperatura del soporte y la de los materiales se encuentren entre 5 °C y 30 °C. Velocidad de viento no superior a 50 km/h. Evitar lluvia en colocación exterior.

**2.3. PREPARACIÓN DE LOS ADHESIVOS.**Adhesivos cementosos: Se prepara según indicaciones del fabricante, con herramientas adecuadas y agua limpia. Se amasa con un batidor a bajas revoluciones hasta la obtención de una pasta homogénea y cremosa y libre de grumos. Se utilizará dentro del periodo de vida útil, y no debe mezclarse de nuevo con agua adicional.

La cantidad de masa elaborada se ajustará al consumo según la velocidad de colocación y las condiciones ambientales.

Adhesivos en dispersión:

Se suelen comercializar en forma de pasta, lista para ser utilizada.

Adhesivo de resinas de reacción:

Se preparan siguiendo las indicaciones del fabricante.

Es de vital importancia utilizar los componentes en sus proporciones adecuadas. Realizar un buen mezclado con el fin de obtener una mezcla homogénea. Se recomienda la utilización de una batidora con mezclador helicoidal.

Es importante preparar y aplicar estos materiales dentro del rango de temperaturas propuesto por el fabricante (entre 10 y 25° C).

#### 2.4. SIMPLE ENCOLADO.

La seleccón de la llana depende de factores tales como tipo de instalación, planitud de la superficie de la colocación, dimensiones de la baldosa y tipo de adhesivo que se va a emplear.

El adhesivo se extiende sobre la superficie de colocación y se peina con llana especificada la cantidad adecuada.

Es importante controlar que la colocación se realizara dentro del tiempo abierto del adhesivo para evitar que se forme una película seca que perjudica la adherencia.

La baldosa cerámica se coloca sobre la capa de adhesivo mediante un movimiento de deslizamiento hasta obtener un total aplastamiento de los surcos que garantiza el macizado y la correcta adherencia de toda la superficie. También se puede aplicar presión con maza de goma.

#### 2.5. DOBLE ENCOLADO.

Se utilizará en:

Revestimientos y pavimentos exteriores.

Colocación de baldosas con formato superior a N 35x35 cm o superficie equivalente. Pavimentos interiores sometidos a cargas dinámicas y estáticas de entidad.

Para aplicarlo:

Por una parte el adhesivo se extiende sobre la superficie de la colocación con llana dentada y por la otra, el adhesivo se extiende por el reverso de la baldosa con la paleta o paletín, o lado recto de la llana.

El espesor final del adhesivo no debe exceder el espesor máximo recomendado. Las baldosas cerámicas se colocan antes de la formación

de una película seca en la superficie del adhesivo.

#### 2.6. COLOCACIÓN DE LAS BALDOSAS.

Antes de proceder a su colocación, es necesario extraer varias piezas de diferentes cajas y verificar chapando una alfombra de 8 a 10 m² para ver el efecto, la tonalidad, calibre y dimensiones. Las baldosas deben colocarse con juntas rectas y regulares entre si. La anchura de la junta depende del formato de la baldosa y el uso y esfuerzo previsible a la que va a ser sometida la instalación. No se aconseja la utilización de una junta de colocación inferior a 1,5 mm. En ningún caso se puede colocar sin junta.

Dentro del tiempo de ajuste se recomienda levantar alguna baldosa para comprobar si se está consiguiendo la superficie de contacto requerida.

Se debe eliminar el adhesivo sobrante de las juntas antes de que endurezca para un correcto rejuntado.

Para formatos rectangulares, la colocación a traba se realizará a un 15% de la longitud de la pieza MÁXIMO.

Debemos proteger el acabado cerámico recién instalado, de las inclemencias del tiempo, heladas y secado prematuro. Los productos deben tener una manipulación cuidadosa, evitando golpes entre piezas al arrastrar las piezas una sobre otra para evitar que puedan dañarse las aristas y ralladuras en la superficie.

Una vez colocado el material es imprescindible una correcta protección de este, con el fin de evitar posibles daños hasta la finalización de la obra.

Este material lo suministramos con una protección de cera para su manipulación al colocarlo, dicha cera se elimina limpiándolo con agua caliente.

### 3. JUNTAS DE MOVIMIENTO.

#### 3.1. JUNTAS ESTRUCTURALES.

Deben respetarse en toda su longitud y anchura, involucrando a todas las capas que constituyen el sistema de recubrimiento. En el caso de ejecución manual, los sellantes deberán tener una deformidad mínima de 15%.

#### 3.2. JUNTAS PERIMETRALES.

Llegarán en profundidad hasta el soporte base o, como mínimo, la capa que actúe como desolidarización. Tendrán una anchura mínima de 6 mm.

#### 3.3. JUNTAS INTERMEDIAS.

En espacios interiores dividir la superficie total con juntas intermedias cada 40 m² como máximo y en exteriores cada 25m². Penetran en profundidad igual que las juntas intermedias. Su anchura se establece en función de la entidad de los movimientos esperados.

### 4. REJUNTADO.

El rejuntado se realizará transcurridas al menos 24 horas desde la colocación de las piezas cerámicas. La aplicación del material de rejuntado se realizará según las instrucciones del fabricante.

Generalmente utilizaremos un material de rejuntado tipo CG2.

Para casos en los que se requiera alta resistencia mecánica, estanqueidad y resistencia química utilizaremos material de rejuntado tipo RG1. Se extenderá la pasta de rejuntado utilizando una llana de goma adecuada rellenando las juntas en toda su profundidad con movimientos diagonales.

### 5. LIMPIEZA.

Para un correcto acabado del revestimiento cerámico, es necesario proceder a la limpieza final de la obra. De este modo se retirarán los restos de cemento, materiales de sellado de juntas y cualquier otro residuo. Para ello, se debe utilizar detergentes desincrustantes ligeramente ácidos y diluidos con agua y mantener por un breve espacio de tiempo en contacto con los vidriados.

**NO UTILIZAR AGENTES DE LIMPIEZA QUE CONTENGAN ÁCIDO COLORHÍDRICO O FLUORHÍDRICO Y SUS DERIVADOS.**

Es conveniente impregnar la superficie con agua limpia previamente a cualquier tratamiento químico para evitar una posible absorción de los agentes utilizados por los materiales de rejuntado.

No deben utilizarse este tipo de productos en las baldosas recién instaladas ya que el ácido reacciona con los materiales de agarre y sellado de juntas no fraguados.

**LA EMPRESA NO SE HARÁ CARGO DE LOS MATERIALES YA COLOCADOS.**

Para facilitar la limpieza y buen uso de nuestros materiales recomendamos el uso de felpudos en las entradas y es aconsejable mantener el pavimento lo más limpio posible para obtener buenos resultados.

**NO SE ADMITIRÁN RECLAMACIONES DE PROBLEMAS DERIVADOS DEL INCUMPLIMIENTO DE ESTAS PREMISAS CUANDO EL MATERIAL YA ESTÁ COLOCADO.**

### MEZCLAS DE PIEDRA Y CRISTAL

#### 1. INFORMACIÓN TÉCNICA Y DE USO.

Baja resistencia al ataque químico.

Tolerancia dimensional de la base cerámica: +0,6%

Buena resistencia al ataque de microorganismos.

Preferiblemente para uso como revestimiento interior.

Tono variable.

No almacenar en zonas húmedas.

#### 2. PREPARACIÓN DE LA SUPERFICIE.

Es imprescindible que la pared de colocación esté perfectamente limpia, seca y nivelada.

#### 3. MATERIAL DE AGARRE.

Para un perfecto agarre se debe utilizar cemento cola C2 o adhesivos epoxidicos, siguiendo en todo momento las instrucciones del fabricante.

#### 4. COLOCACIÓN.

Extender una fina capa de adhesivo sobre la superficie y colocar la pieza antes de que el adhesivo comience a endurecer.

Los restos de adhesivo deben limpiarse antes de que endurezcan utilizando una esponja húmeda.

#### 5. REJUNTADO Y CORTE.

Asegúrese de que el adhesivo está completamente seco antes de rejuntar.

Para el rejuntado siga las instrucciones del fabricante de la pasta utilizada.

Utilice una esponja y agua para limpiar los restos de pasta.

#### 6. LIMPIEZA Y MANTENIMIENTO.

Utilice agua o detergentes neutros con una esponja.

En ningún caso utilice productos abrasivos o anti-cal.

### PIEDRAS PRECIOSAS

#### 1. INFORMACIÓN TÉCNICA Y DE USO.

Baja resistencia al ataque químico.

Solo se usa como revestimiento.

100% natural.

Gran variedad de tonos y colores.

#### 2. PREPARACIÓN DE LA SUPERFICIE.

Es imprescindible que la pared de colocación esté perfectamente limpia, seca y nivelada.

Es recomendable pintar la pared de blanco para minimizar la visualización del adhesivo.

Cuando se coloque en zonas con agua se debe impermeabilizar previamente la pared.

#### 3. MATERIAL DE AGARRE.

Se recomienda el uso del H40, ya que este material sirve a la vez de cola de agarre como de pasta de rejuntado.

### 4. COLOCACIÓN.

El material debe estar perfectamente limpio y seco tanto en la superficie de contacto con la cola como en la cara frontal.

Las piezas se colocan sin tener en cuenta las juntas, deben estar en contacto.

El adhesivo se ha de distribuir por las esquinas y el centro de la pieza.

Una vez colocada la pieza, moverla un poco sobre la pared para rellenar huecos vacios.

En caso de encontrar hueco entre las mallas después de la colocación, cubrir los huecos con piezas sueltas para un buen acabado.

#### 5. REJUNTADO Y CORTE.

Para rejuntar se puede utilizar pasta de rejuntar estándar.

#### 6. LIMPIEZA Y MANTENIMIENTO.

Utilice agua o detergentes neutros con una esponja.

En ningún caso utilice productos abrasivos o antical.

	Revestimiento		Antideslizante
	Pavimento		Retroiluminado
	Material flexible		Porcelánico
	Inkjet		Rectificado
	Pasta blanca		Rectificado abujardado
	Destonificado		Rectificado lapado

www.anjasora.com/caracteristicas-tecnicas



FLOOR TAPE

FLEX TONE

CONCRETE

THE STONES

THE MOSAIC

ON AREA

ANJASORA

Cno. Foyes Ferraes s/n 12110 l'Alcora  
Castellón SPAIN

(+34) 964 367 124 (+34) 964 363 548 anjasora@anjasora.com

[www.anjasora.com](http://www.anjasora.com)